



KS 2

Liquid alarm sensor KS 2 / KS 2.Ex

for non-conductive and conductive media

5-5.3 04.99/11.06

Special Features

Sure detection even of minimal liquid quantities

Integrable in M&C-universal filters and flow chamber

Explosion proof version according to ATEX for zone 0

M&C® Application

Liquid alarm sensors are used in gas sample conditioning systems for monitoring gas cooling and condensate drain-off devices in order to provide protection for downstream analysis instruments. This monitoring device KS 2/KS 2.Ex reliably signals the penetration of non conductive (e.g. alcohol) and conductive (e.g. water) liquid in the event of cooling or condensate drain-off equipment being defective, thus avoiding expensive down time as well as high repair costs for analysis instruments.

In the event of an alarm, power for the sample gas pump must be switched off or a solenoid valve must be switched idle in the sample conditioning system.

M&C® Description

The M&C liquid sensor KS 2/KS 2.Ex works on the principle of capacitive measurement and is suitable for non-conductive and conductive media. A pre-amplifier is integrated in the sensor housing and is connected with the necessary external electronic controller via 2- resp. 3-wire. For KS 2 the required electronic controller is available in various versions, FA1.1; FA1.4 and is described in the separate data sheet 5-6.10.2.

The M&C liquid sensor KS 2.Ex for use in hazardous areas and media should only be applied in connection with electronic controller WE77.Ex1 or KFA6-SR2-Ex1W.

The M&C KS 2/KS 2.Ex liquid sensor is constructed in such a way that any droplets of liquid in the sample gas are attracted directly to the active sensor surface. Even the smallest liquid droplets will trigger a sure and rapid alarm.

The sensors are mounted with the 16mm ø stainless steel body in the GL-25 connector of the universal filter F...-D or the condensate pot TG1 or in the flow chamber LS/KS.

M&C Dimensions

M&C KS 2 / KS 2.Ex liquid sensor

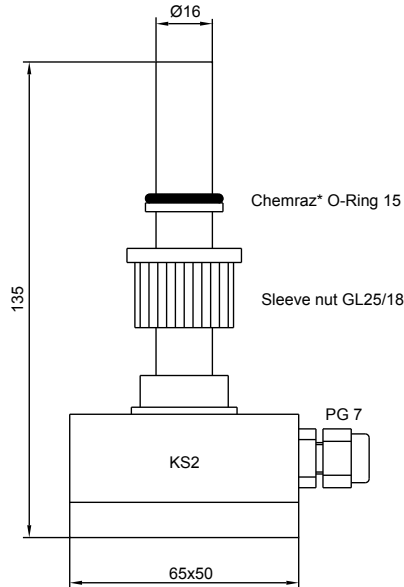

* Chemraz is a trade mark of Greene Tweed

M&C Liquid alarm sensor KS 2 / KS 2.Ex in a universal filter F...-D

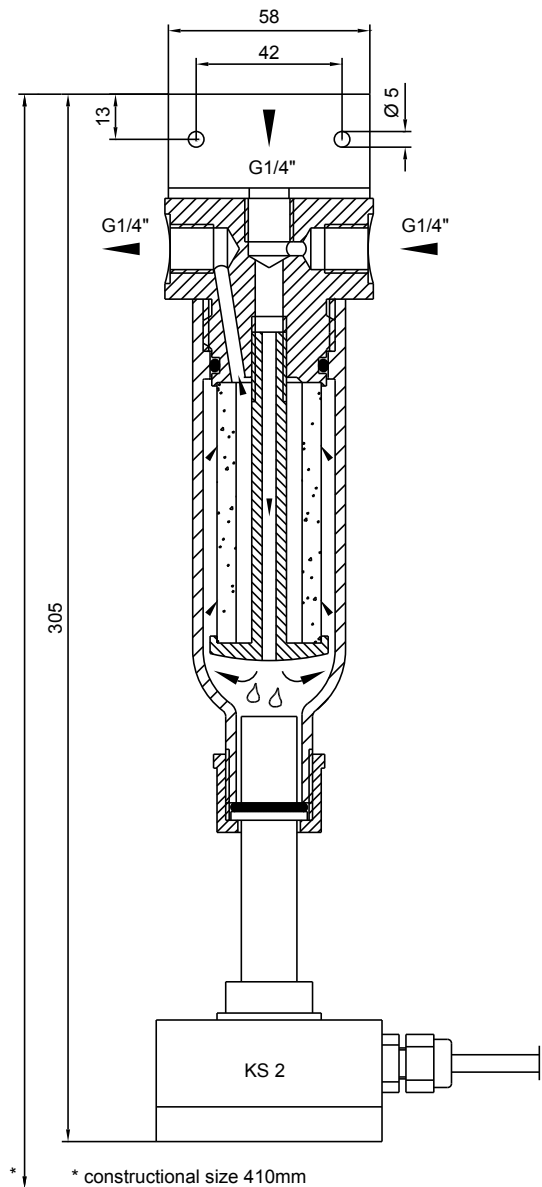

In the event of condensate penetration, the filter housing acts as a buffer vessel preventing immediate liquid penetration.

M&C KS 2..liquid sensor for level monitoring in condensate pot TG1

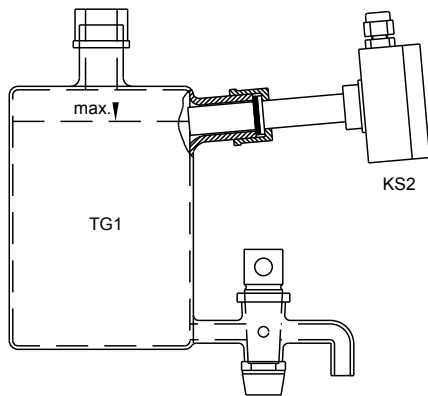

Dimensions in mm

M&C Technical Data

| Sensor | KS 2 | KS 2 Peek | KS 2.EX |
|---|---|---|--|
| Part No. | 03E4100 | 03E4110 | 03E4200 or 03E4210 for mounting in stainl. steel filter FSS...-D 1/2"NPT |
| Pressure | max. 2 bar abs. | max. 11 bar abs. | max. 2 bar abs. |
| Max. operating temperature | 0 bis +60 °C | | 0 bis +50 °C |
| Liquid alarm limit | 1,5 ml | | |
| Material of sample contacting parts | PTFE, Chemraz*, SS316Ti | Peek, Chemraz*, SS316Ti | PTFE, Chemraz*, SS316Ti |
| Sample connection | ø 16 mm | ø 18 mm | ø 16 mm |
| Option sample connection ø 18 mm, Part No.. 03E9400 (fitting for mounting: Part No. 09V2317 GE SS 1/2"NPT-18mm) | for mounting in stainl. steel filter FSS...-D 1/2"NPT | for mounting in stainl. steel filter FSS...-D 1/2"NPT | |
| Power supply | 8-12Vdc, feeding via FA1.1 or FA1.4 | | 8Vdc, max. 2,4mA / operating: <1,4mA = Alarm |
| Method of mounting / mounting position | clamping attachment / any position | | |
| Connection cable, length 1,5 m standard | 3x 0,25 mm ² | | 2x 0,25 mm ² |
| System of protection | IP 54 EN 60529 | | II 1 G EEx ia IIC T6, KEMA 03ATEX1006 |
| Weight | 190 g | | |