



LB-1PV, LB-1SS

Liquid stop LB-1PV and LB-1SS

for protecting gas analysers and gas-phase chromatographs against liquids

5-1.10.9 10.03/11.06

Special Features

- Sure protection against liquid inrush
- Reliable removal of liquid coming through
- Also suitable for high pressures
- Available in stainless steel and PVDF
- Easy change of the hydrophobic protective membrane
- With wall mounting holder

M&C Application

The M&C liquid-stop LB-1.. is suitable for protecting analysers against inrush of liquids out of the gas conditioning unit which is mounted before the analyser. This avoids major damages of the analyser.

The most useful position of the liquid stop LB-1.. is behind the gas conditioning unit, directly before the flowmeter of the analyser.

M&C Description

The hydrophobic protective membrane of the liquid-stop LB-1.. is placed between the two parts of the housing which are screwed together. It is lined with a porous glass filter frit in order to secure stable proportions.

The pore sizes of the protective membrane are designed in such a way that gas molecules and steam can pass through but liquid molecules are retained.

The gas inlet and outlet are positioned in an horizontal line inside the housing. The liquid outlet shows downwards when being mounted.

Due to the horizontal flow direction of the gases and because possible liquids are draining off on the protective membrane due to its gravity, the leaking through of liquids to the analyser is avoided.

Eventually occurring liquid can be let off via a peristaltic pump SR25.1, separator and automatic liquid drain ADS-SS or a condensate vessel TG1 (dip tank). The LB-1 has got a respective connection possibility.

Changing the membrane is easy to handle. The optimum positioning of the sealing O-rings guarantees always a sure sealing of both housing parts.

The filter inlet and outlet can be turned by 180° on the wall mounting holder so that a flexible adaption to local circumstances is possible during moutage.

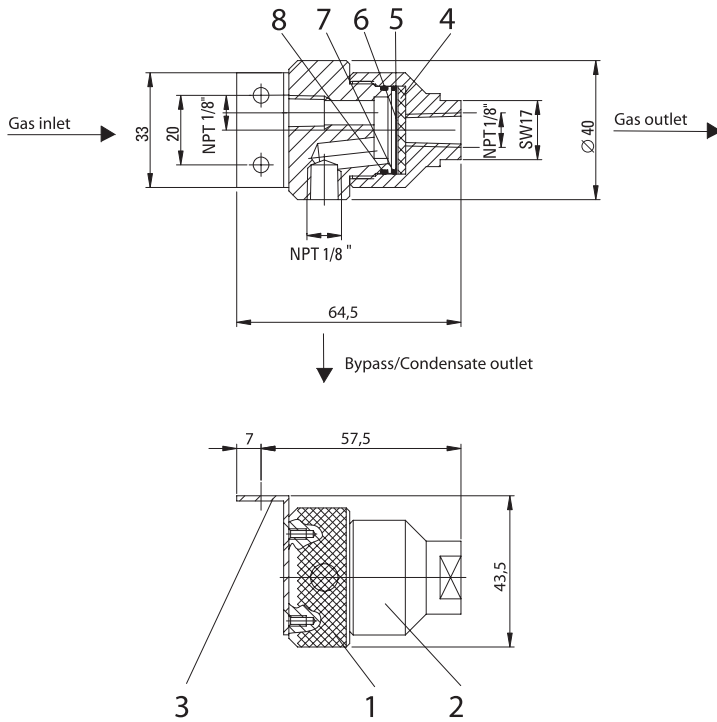

Dimensions in mm

- 1 Upper part of housing
- 2 Lower part of housing
- 3 Holding angle
- 4 Glass filter frit
- 5 Hydrophobic protective membrane
- 6 Flat ring of Teflon
- 7 O-ring FPM
- 8 O-ring FPM

M&C Technical Data

Liquid-stop	LB-1PV	LB-1SS
Part No.	03F4005	03F4000
Gas flow	max. 200 NI/h	
Gas pressure	0,3-2 bar abs. ΔP max. 0,5 bar	0,3 -10 bar abs. ΔP max. 0,5 bar
Differential pressure with clean protection membrane, medium air, 20°C	50 100 mbar 100 200 NI/hr	
Temperature sample gas	max. +80 °C	max. +100 °C
Ambient temperature	0 °C to +60 °C	
Storage temperature	-25 °C to +80 °C	
Stagnant space	4 ml	
Material of gas bearing parts	PVDF, FPM, PTFE, Polyester, glass	1.4571, FPM, PTFE, Polyester, glass
Sample gas / drain connections	NPT 1/8"i DIN ISO 228/1	
Mounting / weight	wall mounting / approx. 0,3 kg	

M&C Examples for application

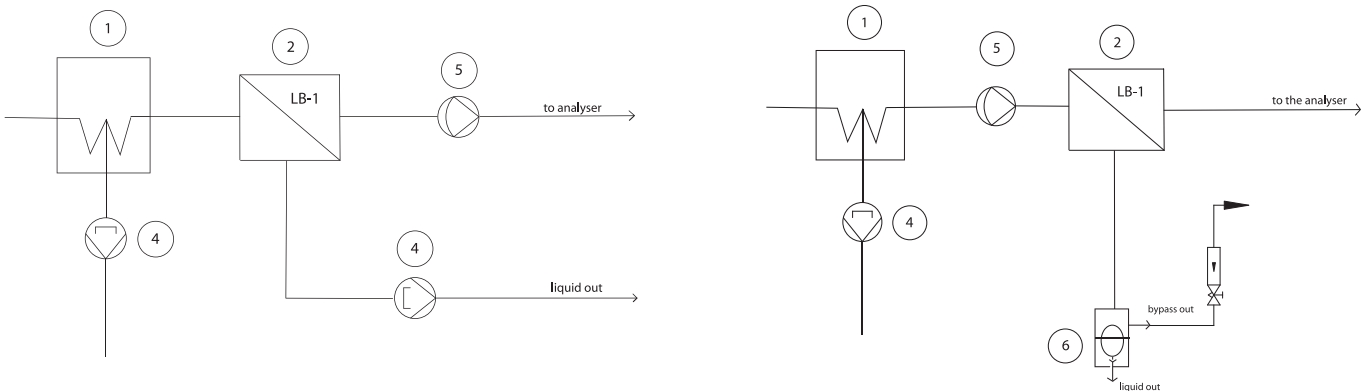

- 1 Gas cooler
- 2 Liquid-stop LB-1
- 4 Liquid drain with peristaltic pump SR25.1
- 5 Gas sample pump
- 6 Separator and automatic liquid drain ADS-SS