



CSS-M

Portable Gas Conditioning Unit Series CSS®

Portable version CSS-M for 70 NI/h gas flow rate
Wall-mounting version CSS-M/W for 70 NI/h gas flow rate

Special Features

- **Portable or for wall-mounting**
- **Gas outlet dew point adjustable from +2 to +15 °C [35.6 to 59 °F]**
- **Water vapor dew point input up to +50 °C [122 °F]**
- **Gas flow rate 1 x 70 NI/h**
- **Dew point stability $\leq \pm 0.1$ °C [± 0.18 °F]**
- **Low weight (11 kg [≈ 24.3 lbs])**

Application

The M&C portable gas conditioning unit CSS-M is designed to carry out precise gas analyses at different locations. The version CSS-M/W is a completely pre-installed compact continuous gas conditioning system for wall-mounting.

Both gas conditioning units are housed in a compact and robust sheet steel housing, so that you can carry out or install your gas analyses quickly, with low maintenance and with maximum operating reliability.

The CSS-M gas conditioning unit is suitable for variable, discontinuous use as well as for continuous operation.

The components built into the CSS-M and CSS-M/W gas conditioning units can be used for standard applications.

Description

The CSS-M and CSS-M/W gas conditioning systems are equipped with a Peltier gas cooler of the ECP series with Jet-Stream heat exchanger, which cools the sample gas to constant +5 °C [41 °F] independent of the ambient temperature. As soon as the operating temperature of $< +8$ °C [46 °F] is reached after commissioning, the sample gas pump N3KPE is automatically switched on with the gas cooler status contact. The peristaltic pump SR 25.2 ensures continuous condensate drainage, making even long-term measurements possible without any problems. The corresponding particle filtration is carried out with the FPF-2-0.3GF ultra-fine filter, which also has an integrated liquid alarm sensor that switches off the sample gas pump in the event of an alarm. An FM40 flow meter is installed in the sample gas outlet. Flow monitoring is optionally available for the CSS-M/W version.

This means that the two gas conditioning units are complete conditioning systems for most gas analysis devices.

Flow scheme CSS-M/(W)



- 1 Gas cooler series ECP
- 2 Fine filter FPF-2-0,3GF, filter porosity 0.3 μm with liquid alarm
- 3 Sample gas pump N3KPE
- 4 Flow meter FM40 (CSS-M/W optional with flow alarm)
- 5 Peristaltic pump SR25.2

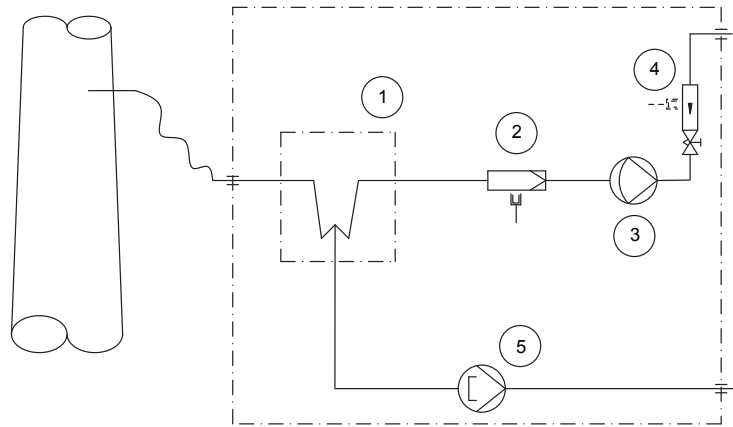

Dimensions CSS-M

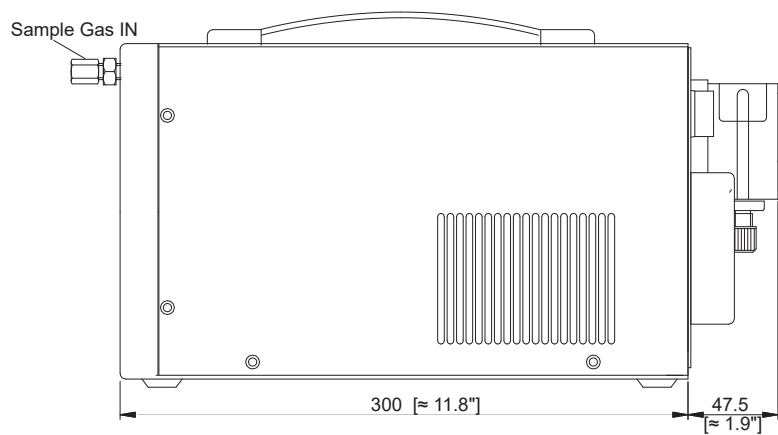
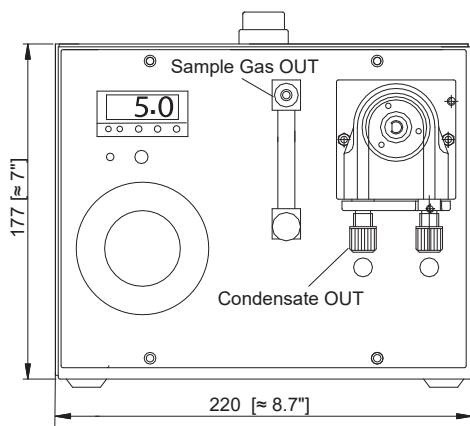

Dimensions CSS-M/W

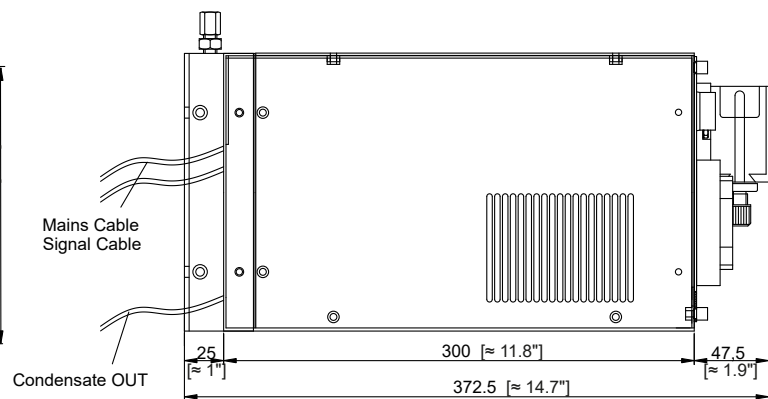
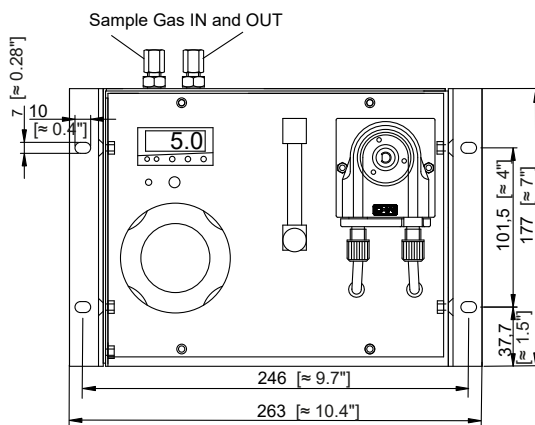

Dimensions in mm [Inches]

Gas Conditioning Unit Series CSS*	Version CSS-M	Version CSS-M/W
Part No. for 230 V/50 Hz version	01G2000	01G2500
Part No. for 115 V/60 Hz version	01G2000a	01G2500a
Sample outlet dew point	Range of adjustment: +2 to +15 °C [36 to 59 °F], factory setting: +5 °C [41 °F]	
Dew point stability	At constant conditions < ±0.1 °C [±0.18 °F]	
Sample inlet temperature*	Max. 80 °C [176 °F]	
Sample inlet dew point*	Max. 50 °C [122 °F]	
Gas flow rate*	Max. 70 NI/h	Max. 70 NI/h
Gas flow alarm	No	Optional Part No. 01G9805
Ambient temperature*	+10 up to +45 °C [50 up to 113 °F]	
Storage temperature	-25 up to +65 °C [-13 to 149 °F]	
Pressure	0.7 bar up to 1.4 bar abs.	
Total cooling capacity*	Max. 40 kJ/h	
Number of gas inlets	1	
Number of gas outlets	1	
Condensate outlet	1	
Medium connections	Tube connection DN 4/6	
Material of sample contacting parts	Glass, PVDF, PVC, Novoprene, Viton®, PPH	
Ready for operation	Approx. 10 min.	
Power supply	230 V/50 Hz or 115 V/60 Hz	
Power consumption	Max. 240 VA	
Fuse protection	4 A t, 5 x 20 mm	
Electrical connection	Cold appliance plug with 2 m cable	Mains cable 3 x 1 mm ² , signal cable 3 x 0.5 mm ² , 3 m length
Status alarm, 1 change over contact, potential-free	No	Contact rating 250 V AC, 2 A, collective alarm for gas flow, liquid and cooler temperature
Case protection	IP20 (DIN 40050, IEC 529)	
Sheet steel housing, design	Portable, color grey, RAL 7035	Wall-mounting, color grey RAL 7035
Equipment dimensions (H x W x D)	177 x 220 x 300 mm [≈ 7.0" x 8.7" x 11.8"]	177 x 263 x 372.5 mm [≈ 7.0" x 10.4" x 14.7"]
Electrical equipment standard	EN 61010	
Weight	Approx. 11 kg [≈ 24.3 lbs]	

* Maximum values in technical data must be rated in consideration of the total cooling capacity at 25 °C [77 °F] ambient temperature and an outlet dew point of 5 °C [41 °F].

Please note: NI/h and NI/min refer to the German standard DIN 1343 and are based on these standard conditions: 0 °C [32 °F], 1013 mbar.

PVDF = Polyvinylidenfluoride

Viton® is a registered trademark used by DuPont Performance Elastomers, USA.