



FP-BF

Humidifier Series FP®

Version FP-BF

Special Features

- Easy change of absorbents
- Refillable with a variety of absorbents
- Condition of liquid visible from outside
- Also for keeping the pressure constant upstream the analyzer
- Optimum humidifying effect
- Low stagnant space
- Wall-mounting bracket
- Various materials available
- Different glass body sizes on request

Application

For the zero point calibration of analyzers that are water vapor cross-sensitive, the humidifier vessel FP-BF is used to humidify the N₂ zero gas upstream of the gas cooler in order to take water vapor cross-sensitivity errors into account accordingly. The zero gas, like the sample gas, is then saturated with water vapor for example, at +5 °C [41 °F].

Test gases with water-soluble components must not be passed via the humidifier vessel.

Description

The M&C humidifier vessel FP-BF features components from the universal filter range and has the same function as the wash bottle FP-W, but the glass body F-120G or F-120G-D with a smaller volume of just 70 ml is used.

A bubbler ensures optimum humidification of the N₂ zero gas. Without having to open the humidifier vessel, the filling level can be assessed from the outside. No tools are required for refilling. The optimum positioning of the O-ring always ensures a secure sealing between the humidifier vessel body and the humidifier vessel head.

The humidifier can be rotated 180° at the wall-mounting bracket. This allows a flexible adaptation of the in- and outlet to local conditions.

For special applications, the FP-BF-GL25 can be provided with a GL 25-12 connection at the bottom of the glass body.

Overpressure at the outlet or under pressure at the inlet of the humidifier must be avoided. Otherwise the liquid will be displaced to the inlet of the wash bottle.

Humidifier FP-BF

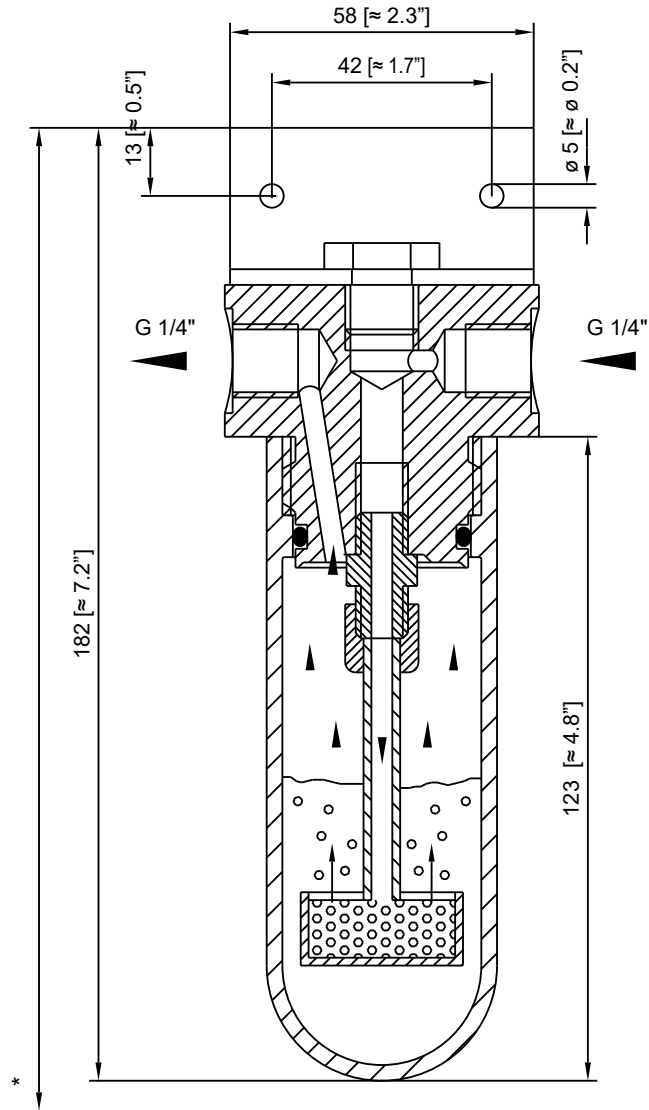

* constructional size 290 [≈ 11.4"]

Dimensions in mm [Inches]

Humidifier FP-BF-GL 25 partial view of glass body with GL 25-12 connector at the bottom

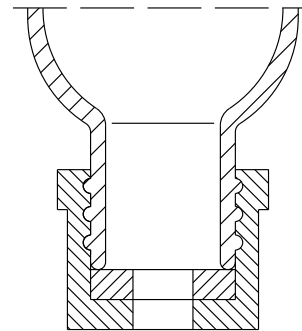

GL 18-6 connector with sealing ring for 6 mm tube

Technical Data

Humidifier	FP-BF	FP-BF-GL25
Part No.	03F5700	03F5750
Sample-contacting parts: head part, connector, tube, o-ring, bubbler, glass body	PVDF FKM, glass	
Contents approx.	70 ml	
Flow rate	Max. 100 NI/h	
Operating temperature	-20 to +80 °C [-4 to 176 °F]	
Storage temperature	-30 bis +110 °C [-22 to 230 °F]	
Operating pressure max.	5 bar abs. at 20 °C [68 °F]	2 bar abs./5 bar abs. with GL connection adapter
Method of mounting	Wall-mounting, position of mounting vertical	
Absorption material	Standard scope of supply without absorption material	
Connection	G 1/4" female DIN ISO 228/1*	G 1/4" female, GL 25-12
Weight	0.3 kg [≈ 2.2 lbs]	

* The dimensions and designation of the screw-in threads correspond to the respective applicable standard. The tolerances of the thread standards are matched to metal threads and cannot be applied to plastic threads.

Please note: NI/h and NI/min refer to the German standard DIN 1343 and are based on these standard conditions: 0 °C [32 °F], 1013 mbar.