

# Temperature Controller

## 70304G

Instruction Manual  
Version 1.02.00



**Dear customer,**

Thank you for buying our product. In this manual you will find all necessary information about this M&C product. The information in the manual is fast and easy to find, so you can start using your M&C product right after you have read the manual.

If you have any question regarding the product or the application, please don't hesitate to contact M&C or your M&C authorized distributor. You will find all the addresses in the appendix of this instruction manual.

For additional information about our products, please go to M&C's website [www.mc-techgroup.com](http://www.mc-techgroup.com). There you can find the data sheets and manuals of our products in German and English.

This Operating Manual does not claim completeness and may be subject to technical modifications.

© 07/2023 **M&C TechGroup** Germany GmbH. Reproduction of this document or its content is not allowed without permission from **M&C**.

With the release of this version all older manual versions will no longer be valid. The German instruction manual is the original instruction manual. In case of arbitration only the German wording shall be valid and binding.

Version: 1.02.00

## List of content

<b>1</b>	<b>General information</b> .....	<b>4</b>
<b>2</b>	<b>Declaration of conformity</b> .....	<b>4</b>
<b>3</b>	<b>Safety instructions</b> .....	<b>5</b>
<b>4</b>	<b>Warranty</b> .....	<b>5</b>
<b>5</b>	<b>Used terms and signal indications</b> .....	<b>6</b>
<b>6</b>	<b>Introduction</b> .....	<b>7</b>
<b>7</b>	<b>Receipt of goods and storage</b> .....	<b>7</b>
<b>8</b>	<b>Description</b> .....	<b>8</b>
<b>9</b>	<b>Dimensions and installation</b> .....	<b>9</b>
<b>10</b>	<b>Technical Data</b> .....	<b>10</b>
<b>11</b>	<b>Electrical connection</b> .....	<b>11</b>
11.1	Connection of temperature sensor .....	12
<b>12</b>	<b>Operating principle</b> .....	<b>12</b>
12.1	Parameter of the user level with factory setting.....	12
<b>13</b>	<b>Change of parameters</b> .....	<b>13</b>
13.1	Removing and activating the level inhibit .....	13
13.2	Menu structure .....	14
13.3	Time Out.....	15
<b>14</b>	<b>Change of the setpoint</b> .....	<b>15</b>
<b>15</b>	<b>Preparations for commissioning</b> .....	<b>15</b>
<b>16</b>	<b>Comissioning</b> .....	<b>15</b>
16.1	Entry and check of controller parameters .....	15
16.2	Self-optimizing (PID action) of control circuit.....	16
16.3	Commissioning with heated foreign components .....	17
<b>17</b>	<b>Low temperature alarm and excess temperature limitation</b> .....	<b>17</b>
17.1	Restarting after excess or low temperature alarm.....	17
<b>18</b>	<b>70304G with mA-output</b> .....	<b>18</b>
18.1	Adjusting Signal type and temperature range.....	18
<b>19</b>	<b>Decommissioning</b> .....	<b>18</b>
<b>20</b>	<b>Maintenance</b> .....	<b>19</b>
<b>21</b>	<b>Proper disposal of the device</b> .....	<b>19</b>
<b>22</b>	<b>Spare part list</b> .....	<b>19</b>
<b>23</b>	<b>Risk assessment</b> .....	<b>20</b>
<b>24</b>	<b>Appendix</b> .....	<b>21</b>
24.1	Parametrization for standard gas sample probes .....	22

## List of Illustrations

Figure 1	Display/control elements.....	8
Figure 2	Housing dimensions and installation dimensions .....	9
Figure 3	Electrical wiring plan.....	11
Figure 4	Menu structure.....	14
Figure 5	Overview risk assessment .....	20

## Head Office

**M&C TechGroup** Germany GmbH ♦ Rehhecke 79 ♦ 40885 Ratingen ♦ Germany

Telephone: 02102 / 935 - 0

Fax: 02102 / 935 - 111

E - mail: [info@mc-techgroup.com](mailto:info@mc-techgroup.com)

[www.mc-techgroup.com](http://www.mc-techgroup.com)

## 1 GENERAL INFORMATION

The product described in this instruction manual has been built and tested in our production facility.

All M&C products are packed to be shipped safely. To ensure the safe operation and to maintain the safe condition, all instructions and regulations stated in this instruction manual need to be followed. This instruction manual includes all information regarding proper transportation, storage, installation, operation and maintenance of this product by qualified personnel.

Follow all instructions and warnings closely.

Read this manual carefully before commissioning and operating the device. If you have any questions regarding the product or the application, please don't hesitate to contact M&C or your M&C authorized distributor.

## 2 DECLARATION OF CONFORMITY



The product described in this operating manual complies with the following EU directives:

### EMV-Instruction

The requirements of the EU directive 2014/30/EU "Electromagnetic compatibility" are met.

### Low Voltage Directive

The requirement of the EU directive 2014/35/EU "Low Voltage Directive" are met.

The compliance with this EU directive has been examined according to DIN EN 61010.

### Declaration of conformity

The EU Declaration of conformity can be downloaded from the **M&C** homepage or directly requested from **M&C**.

### 3 SAFETY INSTRUCTIONS

**Follow these basic safety procedures when mounting, starting up or operating this equipment:**

Read this operating manual before starting up and use of the equipment. The information and warnings given in this operating manual must be heeded.

Any work on electrical equipment is only to be carried out by trained specialists as per the regulations currently in force.

The installation and commissioning of the device must conform to the requirements of VDE 0100 (IEC 364) 'Regulations on the Installation of Power Circuits with Nominal Voltages below 1000 V' and must be in compliance with all relevant regulations and standards.

Check the details on the type plate to ensure that the equipment is connected to the correct mains voltage.

Protection against touching dangerously high electrical voltages:

Before opening the equipment, it must be switched off and hold no voltages. This also applies to any external control circuits that are connected.

The device is only to be used within the permitted range of temperatures and pressures.

Consider IP-protection-class when choosing installation site.

Do not use the device in hazardous areas.

Installation, maintenance, inspections and any repairs of the devices must be carried out only by qualified skilled personnel in compliance with the current regulations.

### 4 WARRANTY

In case of a device failure, please contact immediately M&C or your M&C authorized distributor.

We have a warranty period of 12 months from the delivery date. The warranty covers only appropriately used products and does not cover the consumable parts. Please find the complete warranty conditions in our terms and conditions.

The warranty includes a free-of-charge repair in our production facility or the free replacement of the device. If you return a device to M&C, please be sure that it is properly packaged and shipped with protective packaging. The repaired or replaced device will be shipped free of delivery charges to the point of use.

5 USED TERMS AND SIGNAL INDICATIONS



**Danger**

This means that death, severe physical injuries and/or important material damage will occur in case the respective safety measures are not fulfilled.



**Warning**

This means that death, severe physical injuries and/or important material damage **may occur** in case the respective safety measures are not fulfilled.



**Caution**

This means that minor physical injuries **may occur** in case the respective safety measures are not fulfilled.

**Caution**

Without the warning triangle means that a material damage may occur in case the respective safety measures are not met.



**Note**

These are important information about the product or parts of the operating manual which require user's attention.

**Qualified Personnel**

These are persons with necessary qualification who are familiar with installation, use and maintenance of the product.



High voltages!

Protect yourself and others against damage which might be caused by high voltages.



Wear protective gloves!

Working with chemicals, sharp objects or extremely high temperatures requires wearing protective gloves.



Use foot protection



Use safety helmet and full protective goggles

## 6 INTRODUCTION

The compact microprocessor-controlled temperature controller type **70304G** is mainly used for M&C components that have no temperature controller in their standard specification. If the temperature controller is ordered together with an M&C component, he already is parameterized and pre-programmed.

He has an adjustable sensor input for all common temperature sensors, and he can be used as a programmable two or three step or continuous and self-optimizing controller with PID structure.

## 7 RECEIPT OF GOODS AND STORAGE

The temperature controller is a complete pre-installed unit.

- Please take the temperature controller and possible special accessories carefully out of the packaging material immediately after arrival and compare the goods with the items listed on the delivery note!
- Check the goods for any damage caused during delivery and, if necessary, notify your transport insurance company without delay of any damage discovered!



**Note**

The equipment should be stored in a protected, frost-free room!

8 DESCRIPTION

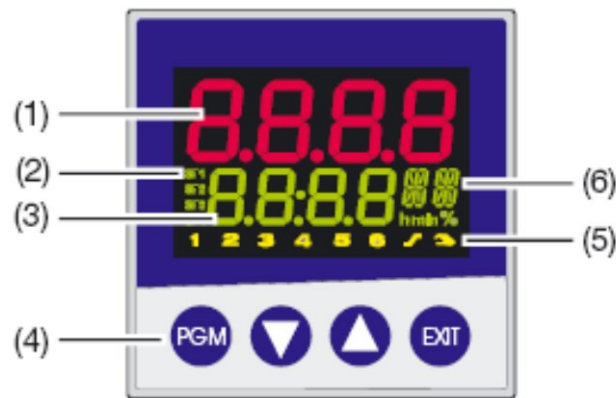

- |  |   |
|--|---|
| <p>(1) <b>Actual value display</b><br/>red, 10 mm high, 4 digits</p> <p>(2) <b>Active Setpoint</b><br/>Factory setting SP1</p> <p>(3) <b>Setpoint</b><br/>Four digits, green; decimal place is configurable.<br/>Also used for operator prompting (display of parameter and level symbols)</p> | <p>(4) <b>PGM-key</b> in order to select parameters<br/> <input type="checkbox"/> in order to change values<br/> <input type="checkbox"/> in order to change values<br/> <b>Exit-key</b> in order to leave the levels</p> <p>(5) <b>Indication</b><br/>yellow for<br/>         - Switch status of binary outputs 1 – 6 (display lights up = on)<br/>         - ramp/program function is active<br/>         - manual operation is active</p> <p>(6) <b>16-segment display for the unit °C / °F</b><br/>factory setting °C</p> |
|--|---|

Figure 1 Display/control elements

## 9 DIMENSIONS AND INSTALLATION

The controller type **70304G** (Part No. 01B8451 230 V; 01B8451a 115 V) consists of the controller plug-in module type 703 (Part No. 01B8401) and a 15 A solid-state relay. These form a complete control unit in a painted metal wall-mounting housing with screwed on cooling unit.

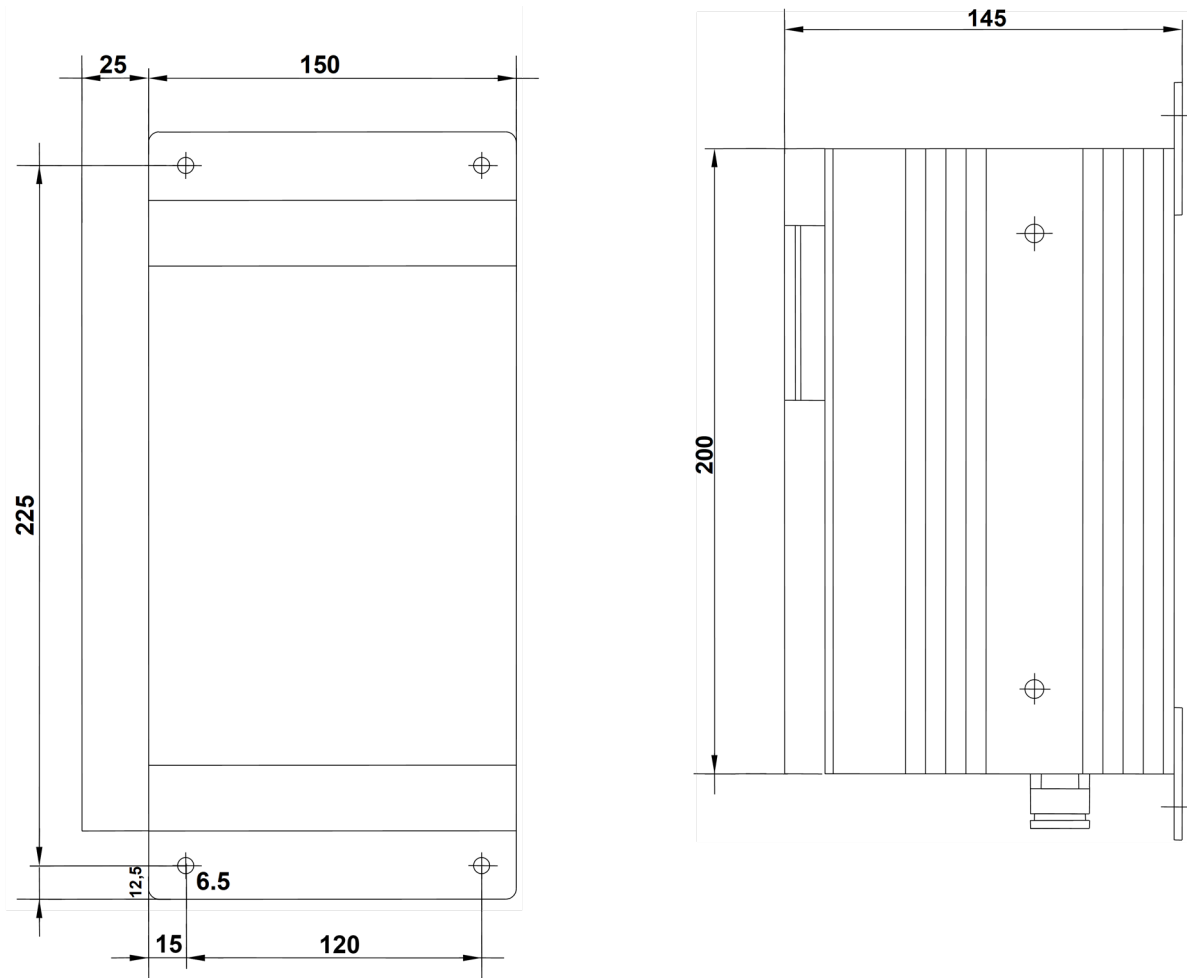

Figure 2 Housing dimensions and installation dimensions

## 10 TECHNICAL DATA

Temperature controller type 70304G	230 V/50 Hz	115 V/60 Hz
Part No.	01B8451	01B8451a
Temperature sensor	Resistance thermometer, thermocouple	
Logic output	0/12 V DC, max. 30 mA to an external solid state relay	
Switching capacity solid state relays	Max. 15 A (overtemperature limiter with continuous cut off)	
Control mode	PID	
Status alarm	Low temperature alarm: 1 contact NO, potential free, contact rating 250 V AC, 3 A	
Indicators	measuring temperature: 4 digits 7 Seg LED red 10 mm; setting value: as listed before but 7.0 mm; ON operation, ramp function on, 2 alarms	
Temperatures	Ambient 0 -50 °C; storage -30 to +70 °C	
Climatic conditions	< 90 % r.H., dew allowed	
Electrical connections	4 mm <sup>2</sup>	
Power supply	230 V 50/60 Hz 3450 VA	115V 50/60 Hz 1725 VA
Housing material	Steel, white lacquered	
Housing version	Wall mounting housing	
Weight / Protection	3.7 kg/IP65 EN 60529	
<b>Optional:</b> Controller with mA-outlet for actual value	01B8453	01B8453a

## 11 ELECTRICAL CONNECTION



**Warning**

An incorrect system voltage can damage the unit. When establishing electrical connection, ensure that the system voltage corresponds to the voltage specified on the rating plate!



**Note**

For the erection of power installations with rated voltages up to 1000 V, the requirements of VDE 0100 and relevant standards and specifications must be observed! The supply circuit of the unit must be provided with a fuse of 16 AT (time-delayed fuse for overcurrent protection); the electrical values are shown in the technical data.

Electrical connection can take place after removal of the front cover as shown in the diagram below on the internal terminal strip. The cover can be removed by loosening the four screws visible on the front cover. Provided on the underside of the housing are four PG 13.5 glands through which the cables can be inserted as shown in Figure 3. Figure 3 shows the electrical wiring diagram for the controller type **70304G**.

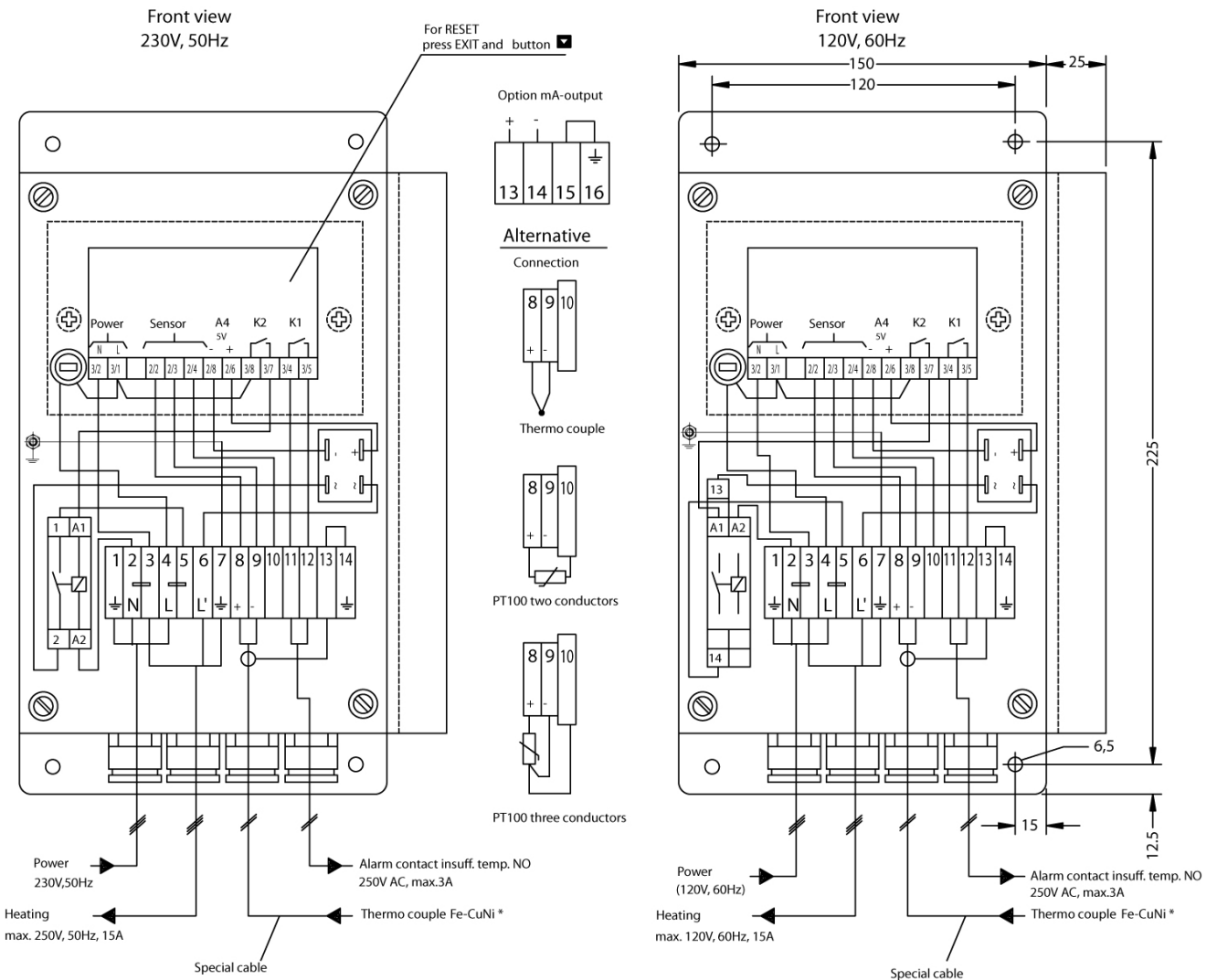

**Figure 3** Electrical wiring plan

## 11.1 CONNECTION OF TEMPERATURE SENSOR

Connection of the temperature sensor depends on the type of sensor used and varies for Pt100 or thermocouple (see Figure 3). For connection purposes, a shielded cable must be used. For a thermocouple, an appropriate compensating cable conforming to DIN 43714 must additionally be used.

## 12 OPERATING PRINCIPLE

Operating and programming of the controller takes place on two levels. On the first level for normal operation, alarms can be reset or in case of starting up a control circuit, self-optimizing is activated.

Underneath there is the user level. All of the important adjustments of the controller are combined on the user level and can be changed after removing the level inhibit.

### 12.1 PARAMETER OF THE USER LEVEL WITH FACTORY SETTING

- Setpoint **SP**, factory setting = **180 °C**
- Max. excess temperature difference to the setpoint **ALSE**, factory setting = **10 °C**. In case of exceeding, a cut off of the controller with lock and an alarm signal takes place.
- Max. low temperature difference to the setpoint **Lo-t**, factory setting = **10 °C**. In case of falling below, an alarm signal takes place
- Limit comparator **Lfun**, factory setting = **2**: for controller with ramp function, 6: for controller without ramp function, other values are not adequate for the operation of M&C products
- Function of the controller **Fnct**, factory setting = **1**: ramp function, 0: fixed-setpoint controller. Other values are not adequate for the operation of M&C products.
- Ramp slope resp. increase of temperature in °C/min (°F/min) **rASL**, factory setting = **30**
- Sensor type **SenS**, factory setting = **2**: Resistance thermometer in 2-wire circuit
  - 0**: no function
  - 1**: Resistance thermometer in 3-wire circuit
  - 2**: Resistance thermometer in 2-wire circuit
  - 4**: Thermocouple



- Linearization **Lin**, factory setting = **1**, Pt100
  - 1: Pt100
  - 2: Pt500
  - 3: Pt1000
  - 7: NiCr-CuNi E
  - 8: Cu-CuNi T
  - 9: Fe-CuNi J
  - 10: Cu-CuNi U
  - 11: Fe-CuNi L
  - 12: NiCr-Ni K
  - 13: Pt10Rh-Pt S
  - 14: Pt13Rh-Pt R
  - 15: Pt30Rh-Pt6Rh B

## 13 CHANGE OF PARAMETERS



To change parameters the level inhibit on the user level has to be removed.

### 13.1 REMOVING AND ACTIVATING THE LEVEL INHIBIT

To remove the level inhibit, act as follows:

- Standard display (below setpoint, up actual value) has to be visible.
- Press key PGM and  simultaneously for 5 seconds, display = **Code 3** (all levels are locked)
- Press PGM
- Change value from **3** to **2** with key 
- The value is blinking after 2 seconds, and the change is taken over
- The user level is unlocked now
- Press **EXIT**

To activate the level inhibit, act as follows:

- Standard display (below setpoint, up actual value) has to be visible.
- Press key PGM and  simultaneously for 5 seconds, display = **Code 2** (all levels are locked)
- Press PGM
- Change value from **2** to **3** with key 
- The value is blinking after 2 seconds, and the change is taken over
- The user level is locked now  
Press **EXIT**

### 13.2 MENU STRUCTURE

Generally:

- Changing to the user level with PGM-key (display = User)
- To choose the first parameter press PGM-key again (display = SP)
- Changing to the next parameter with -key
- Back to the standard display press EXIT-key (2 x)

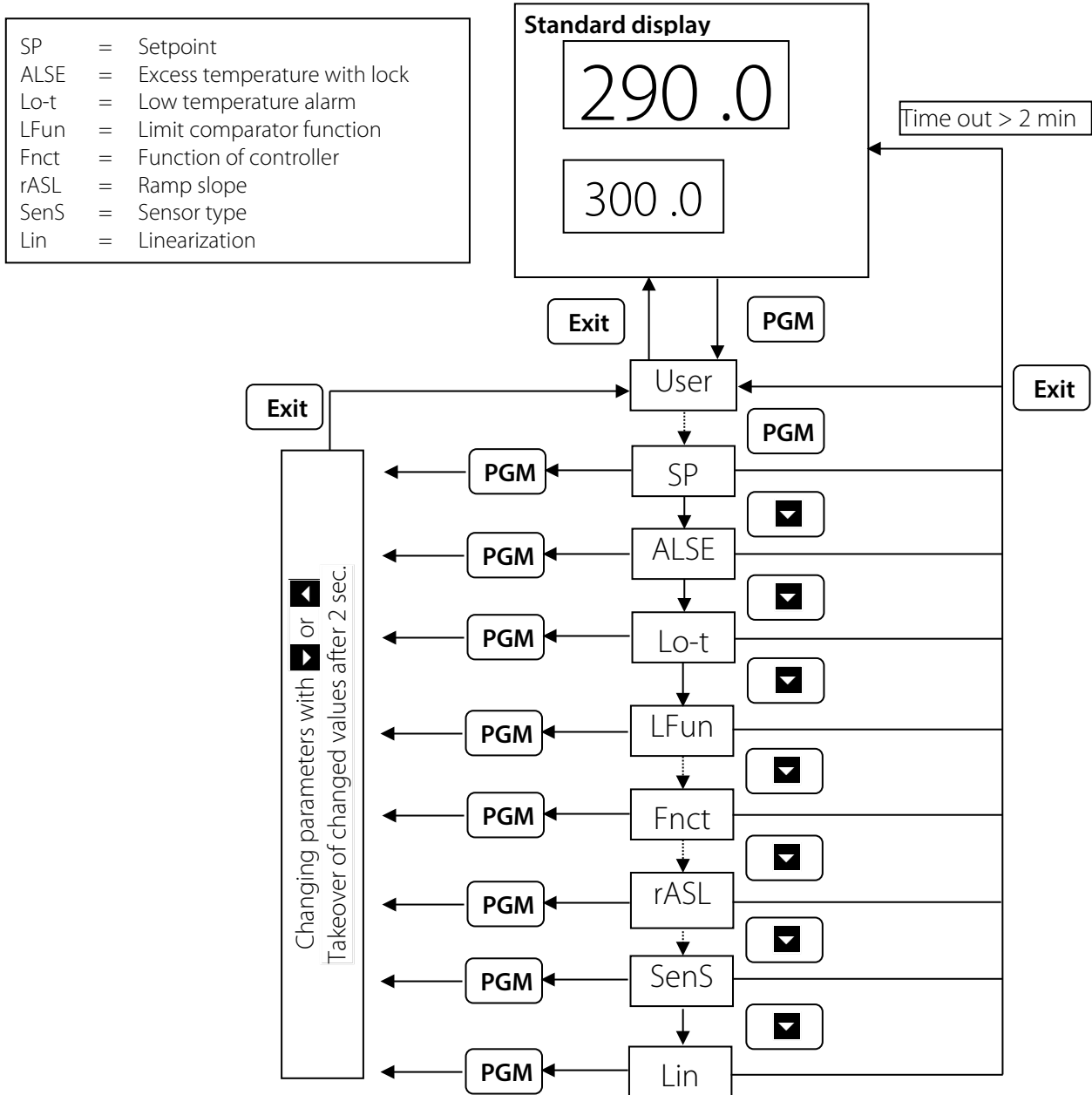

Figure 4 Menu structure

### 13.3 TIME OUT

If no operation takes place, the controller automatically returns to the standard display after about 2 minutes using any changed parameters.

## 14 CHANGE OF THE SETPOINT



**Warning**

Observe the maximum temperature of the device to be controlled to avoid damaging the same.

The setpoint value should not be reduced in one step by more than the entered alarm value, as the setpoint value will be outside the set alarm window. This will result in the generation of an overtemperature alarm, which will permanently deactivate the heating circuit.

For restart:

- Let cool down the device below the new setpoint;
- Press **EXIT** and -key or
- Reset of the low temperature alarm by switching off and on of the mains voltage.

## 15 PREPARATIONS FOR COMMISSIONING

Before initial startup, all plant- and process-specific safety measures must be observed. It is mandatory for the operator to complete the enclosed risk assessment of the product.

The gas exposure risk must be assessed by the operator with regard to the hazards posed by process and calibration gas and the setup at the installation site (e.g. tubing, system cabinet/container/plant). If the risk assessment reveals increased exposure hazards, further measures are required.

A visible label must be attached to the installation site in accordance with the risk assessment provided by the operator.

## 16 COMISSIONING

### 16.1 ENTRY AND CHECK OF CONTROLLER PARAMETERS



**Note**

For the entry and check of controller parameters, the heating of the respective M&C component must not yet be connected.

In any event prior to commissioning, the parameters SP (setpoint), SenS (sensor type) and Lin (linearization depending on the particular M&C unit must be entered. The remaining parameters should correspond with the factory setting.



If the heating should already be connected, isolate the unit from the power supply before disconnecting the heating!

## 16.2 SELF-OPTIMIZING (PID ACTION) OF CONTROL CIRCUIT

The controller type **70304G** includes the option of self-optimizing. For the initial operation of all **M&C** components, this is necessary.







For self-optimizing of the control circuit, the heating of the respective M&C component must be reconnected to the appropriate controller terminals (see Figure 3).



Before connecting the heating, isolate the unit from the power supply!

Before self-optimizing firstly the ramp function has to be deactivated ( $Fnct = 0$ ) and the parameter for the limit comparator has to be changed ( $Lfun = 6$ ). See also chapter 13.

The self-optimizing function can be activated as follows:

- After cable connection (Figure 3), switch on the supply.
- When the actual value (top display, red indicator) reaches the setpoint value (bottom display, green indicator), press  +  keys simultaneously for longer than 2 seconds. The word "**tUnE**" now flashes in the setpoint value display and the self-optimizing function is activated.
- Self-optimization has finished when the display changes to the standard display. The time of self-optimizing depends on the control circuit.
- To cancel the self-optimization, press the keys  +  simultaneously.

After self-optimization reactivate the ramp function ( $Fnct = 1$ ) and reset the parameter for the limit comparator ( $Lfun = 2$ ).

### 16.3 COMMISSIONING WITH HEATED FOREIGN COMPONENTS

Commissioning takes place as described in chapters 16.1 and 16.2. The parameters for **SP, ALSE, Lo-t, Lfun, Fnct, rASL, SenS** and **Lin** must be entered for the respective component (see chapter 12 and 13).

The parameter **rASL** must be determined. For this purpose, the time for heating the unit until the setpoint temperature is reached must be measured.

This is then followed by (empirical value): **rASL = 0.8 (setpoint temperature/rate of temperature rise)**

The calculated rASL value must be entered rounded.

After entering the parameters, a self-optimization, described in chapter 16.2, has to be operated.

## 17 LOW TEMPERATURE ALARM AND EXCESS TEMPERATURE LIMITATION

The controller type **70304G** is adjusted and wired so that it uses relay 2 as a low temperature alarm output and relay 1 as an excess temperature limitation with permanent deactivation.

Both alarms are indicated on the controller front panel by the respective number (1 or 2) **extinguishing**. This takes place if the setpoint temperature is higher or lower than 10 °C.

Operating state		1	2	3
Heating up		off	on	on/off
Normal	Heating on	on	on	on
	Heating off	on	on	off
<b>Alarm</b>		X	<b>off</b>	X

### 17.1 RESTARTING AFTER EXCESS OR LOW TEMPERATURE ALARM

In order to restart the unit after a temperature alarm with permanent deactivation, the cause of the alarm must initially be remedied.

**With not programmed ramp functions**, an alarm reset must take place as follows:

- Press **EXIT** and  keys simultaneously or
- Switch off and on the mains voltage.

**With programmed ramp functions**, an alarm reset must take place as follows:

- If the actual value is < ±10 °C to the setpoint press **EXIT** and  keys simultaneously or
- Switch off and on the mains voltage.



In case of an alarm reset by switching off and on the mains voltage the ramp start value is equivalent to the actual value.

## 18 70304G WITH mA-OUTPUT

The controller **70304G** is also available with a mA-output. This output is also configurable. The output signal and the temperature range are adjustable.

### 18.1 ADJUSTING SIGNAL TYPE AND TEMPERATURE RANGE

To adjust the signal type and temperature range:

PGM-key, **USEr**,  up to **Conf**, PGM-key,  up to **OutP**, PGM-key,  up to **OutA**, PGM-key, **Out6**, PGM-key, **Fnct**,  **SiGn**, PGM-key, **SiGn** blinking, with  or  choose signal type:

0 = 0-10 V

1 = 2-10 V

2 = 0-20 mA

3 = 4-20 mA (factory setting)

Takeover of the adjusted value takes place after 2sec.

 up to **0Pnt** (zero point of the temperature range): PGM-key, **0Pnt** blinking, with  or  adjust zero point (0,0 = factory setting).

 up to **End** (end point of the temperature range): PGM-key, **End** blinking, with  or  adjust end point (200,0 = factory setting).

## 19 DECOMMISSIONING



### Note

The place of installation of the temperature controller must be protected from frost also in the time in which the unit is deactivated.

No particular measures are necessary for brief decommissioning of the temperature controller.

## 20 MAINTENANCE

Before carrying out maintenance work, the system and process-specific safety measures must be observed!



**Warning**

High voltage.

Before opening the housing, isolate the temperature controller from the power supply!

The temperature controller does not require any special maintenance.

The temperature controller should be cleaned with compressed air from time to time depending on the degree of pollution of the ambient air.

## 21 PROPER DISPOSAL OF THE DEVICE

At the end of the life cycle of our products, it is important to take care of the appropriate disposal of obsolete electrical and non-electrical devices. To help protect our environment, please follow the rules and regulations of your country regarding recycling and waste management.

## 22 SPARE PART LIST

Temperature controller 70304G (C) Consumable parts, (R) Recommended spare parts, (S) Spare parts			Recommended quantity being in operation [years]		
			1	2	3
		V/E/T			
01B8401	Electronic PID temperature controller type 703 with self-optimizing function, front-mounting enclosure Sensor input: resistance thermometer or thermocouple Output: 0/12 V for Solid-State relay control Status signal output: 1 contact NO for excess and low temperature alarm Alarm relay switching capacity: 250 V AC, 3 A Dimensions: 48 x 48 x 100 mm Power supply: 230/115 V, 50/60 Hz	T			
95A9015	Solid State Relay 25 A Input 8/15 V DC Output max. 264 V AC, 25 A	E			1
EZR0013	Relay for controller 70304, 230 V AC	T			
EZR0010	Relay for controller 70304, 110 V AC	T			

## 23 RISK ASSESSMENT

The risk assessment provided in this chapter is intended for all work activities on the product. The hazards can occur in the work steps of assembly, commissioning, maintenance, disassembly and in the event of a product fault. During normal operation, the product is protected by a system cabinet or appropriate covers.

Only qualified personnel is permitted to perform the work. The following minimum knowledge is required for the work:

- Employee instruction provided in process engineering
- Employee instruction provided in electrical engineering
- Detailed knowledge of the instruction manual and the applicable safety regulations

The product complies with the current regulations according to state-of-the-art science and technology. Nevertheless, not all sources of danger can be eliminated while observing technical protective measures. Therefore, the following risk assessment and the description of exposure hazards refer to the work steps mentioned above.

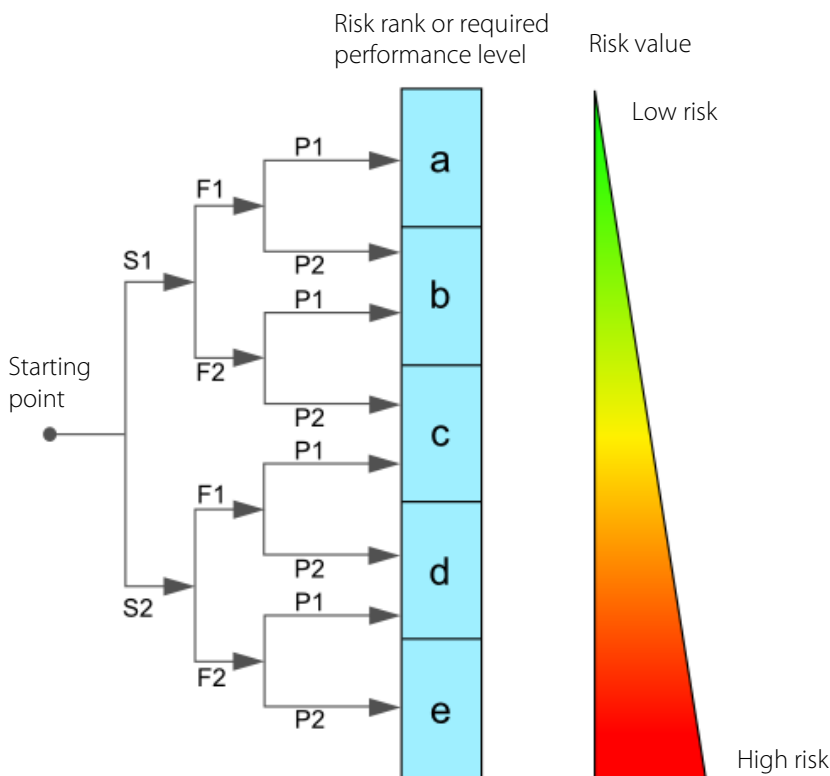

### Severity of injury:

S1 = 1 = minor (reversible injury)

S2 = 2 = serious (irreversible injury, death)

### Frequency and duration:

F1 = 1 = infrequent or short exposure to hazard

F2 = 2 = frequent (more than once per hour/shift)

### Possibility of preventing or limiting the damage

P1 = 1 = possible

P2 = 2 = hardly possible

**Figure 5 Overview risk assessment**

**Caution electric shock****Risk rank - group C**

When installing high-power systems with nominal voltages of up to 1000 V, the requirements of VDE 0100 and their relevant standards and regulations must be observed! This also applies to any connected alarm and control circuits. Before opening the products, they must always be disconnected from the power supply.

**Caution crushing hazard****Risk rank - group A**

The work must be performed by trained personnel only.

This applies to products weighing less than < 40 kg [≈ 88.2 lbs]:

The product can be transported by 1 to 2 person(s). The instructions for appropriate personal protective equipment (PPE) must be observed.

The weight specifications are contained in the technical data of this product.

Furthermore, the work safety regulations of the operator must be observed.

**24 APPENDIX**

- Parametrization for **M&C**-products.



For further product documentation, please see our internet catalogue:

[www.mc-techgroup.com](http://www.mc-techgroup.com)

## 24.1 PARAMETRIZATION FOR STANDARD GAS SAMPLE PROBES

SP2000-H..., SP2200-H..., SP2300-H..., SP2400-H..., SP2500-H..., SP2600-H..., SP2000-H/DIL...

Probe Version with	PT100 180 °C	PT100 320 °C	Thermo couple K 180 °C	Thermo couple K 320 °C	Thermo couple J 180 °C	Thermo couple J 320 °C
SP	180	320	180	320	180	320
ALSE	30	30	30	30	30	30
Lo-t	30	30	30	30	30	30
Lfun	2	2	2	2	2	2
Fnct	1	1	1	1	1	1
rASL	3	3	3	3	3	3
SenS	2	2	4	4	4	4
Lin	1	1	12	12	9	9

Parametrization for heated sample tubes :

SP30-H..., SP35-H...

Version with	PT100 200 °C	Thermo couple K 200 °C	Thermo couple K 320 °C	Thermo couple J 200 °C	Thermo couple J 320 °C
SP	200	200	320	200	320
ALSE	30	30	30	30	30
Lo-t	30	30	30	30	30
Lfun	2	2	2	2	2
Fnct	1	1	1	1	1
rASL	3	3	3	3	3
SenS	2	4	4	4	4
Lin	1	12	12	9	9

Parametrization for dilution probes for the US-market :

SP2000-H/DIL..., SP2006-H/DIL..., SP2006-H280/DIL

Probe version with	PT100 180 °C	PT100 280 °C	Thermo couple K 180 °C	Thermo couple K 280 °C	Thermo couple J 180 °C	Thermo couple J 280 °C
SP	180	280	180	280	180	280
ALSE	30	30	30	30	30	30
Lo-t	30	30	30	30	30	30
Lfun	2	2	2	2	2	2
Fnct	1	1	1	1	1	1
rASL	3	3	3	3	3	3
SenS	2	2	4	4	4	4
Lin	1	1	12	12	9	9