

Gas Conditioning Unit Series CSS[®]

CSS-M/W wall mount

Instruction Manual
Version 1.03.01

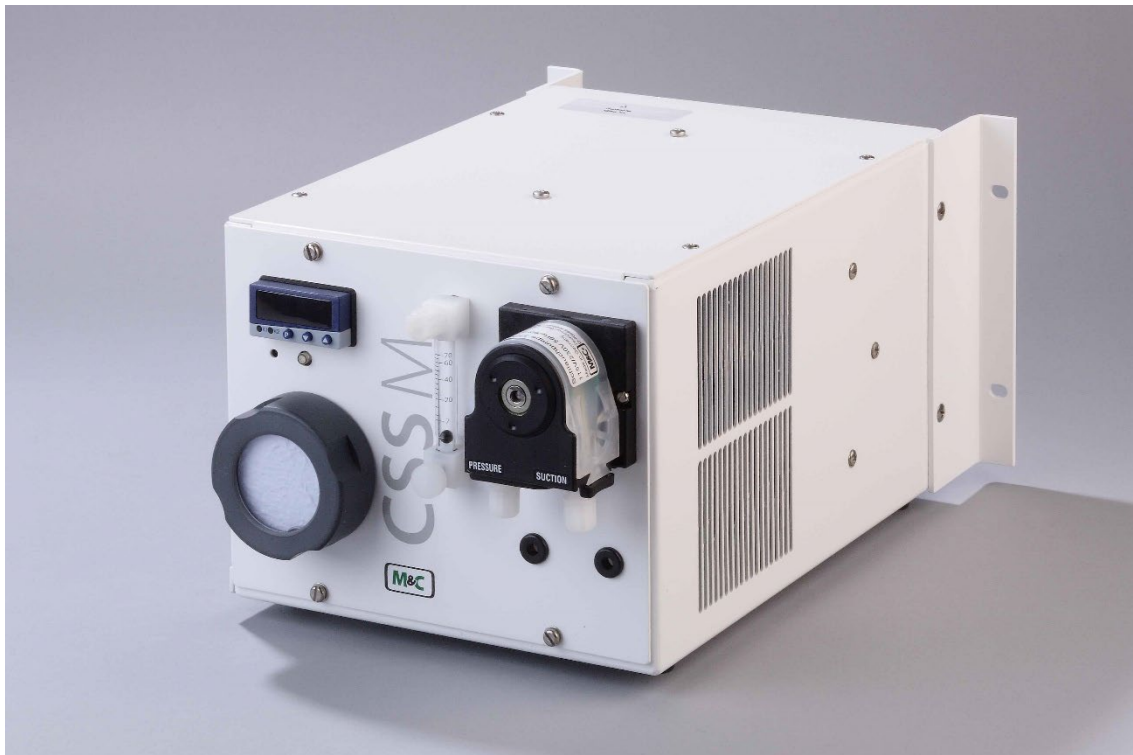

**Dear customer,**

Thank you for buying our product. In this instruction manual you will find all necessary information about this M&C product. The information in the instruction manual is fast and easy to find, so you can start using your M&C product right after you have read the manual.

If you have any question regarding the product or the application, please don't hesitate to contact M&C or your M&C authorized distributor. You will find all the addresses in the appendix of this manual.

For additional information about our products and our company, please go to M&C's website www.mc-techgroup.com. There you will find the data sheets and manuals of our products in German and English.

This Operating Manual does not claim completeness and may be subject to technical modifications.

© 02/2024 **M&C TechGroup** Germany GmbH. Reproduction of this document or its content is not allowed without permission from **M&C**.

CSS® is a registered trade mark.

With the release of this version all older manual versions will no longer be valid.

The German instruction manual is the original instruction manual. In case of arbitration only the German wording shall be valid and binding.

Version: 1.03.01

Contents

1	General information	5
2	Declaration of conformity	5
3	Safety instructions	6
3.1	Intended use	6
4	Warranty	7
5	Used terms and signal indications	7
6	Introduction	9
7	Application	9
8	Technical Data	10
9	Description	11
10	Receipt of merchandise and storage	12
11	Installation instructions	12
12	Hose connections	13
13	Electrical connections	14
14	Preparations for commissioning	15
15	Starting up	15
15.1	Cooler regulation	16
15.2	Pump switch	16
16	Closing down	18
17	Maintenance	18
17.1	Replacement of the filter element and the O-ring	19
17.2	Dismounting the sample gas pump for examination or maintenance	20
17.3	Maintenance of the integrated peristaltic pump type SR25.2	20
17.3.1	Mounting instructions for peristaltic pump	21
17.3.2	Changing the pump tubing	22
17.3.3	Changing contact pulleys and springs	23
17.3.4	Reassembly of the driver	25
17.3.5	Cleaning the pump head	25
17.3.6	Repair information for integrated peristaltic pump type SR25.2	25
18	Operating of the built-in electronic temperature controller	26
18.1	Temperature controller version until March 2022	26
18.1.1	Changing the set value	27
18.2	Temperature controller version starting April 2022	27
18.2.1	Changing the set value	27
18.3	Temperature controller version starting June 2023	28
18.3.1	Changing the set value	28
19	Trouble shooting	29
20	Proper disposal of the device	30
21	Spare part list	31
22	Risk assessment	32
23	Appendix	34

List of Illustrations

Figure 1	Scheme of gas flow	9
Figure 2	Dimensions CSS-M/W	11
Figure 3	Hose connections CSS-M/W	13
Figure 4	Electronic board CSS-M/W.....	17
Figure 5	Replacement of the filter element and the O-ring	19
Figure 6	SR25.2: Mounting distance between front panel and pump motor.....	21
Figure 7	Changing the pump tubing.....	22
Figure 8	Different pump tube sizes.....	23
Figure 9	Disassembly of pump head and driver	23
Figure 10	Check of axes and rolls	24
Figure 11	Hysteresis behavior of the temperature alarm at factory settings	26
Figure 12	Front view of the temperature controller version until 03.2022	26
Figure 13	Front view of the temperature controller version starting 04.2022	27
Figure 14	Front view of the temperature controller version starting 06.2023	28
Figure 15	Overview risk assessment	32
Figure 16	Circuit diagram CSS-M/W.....	35

Head Office

M&C TechGroup Germany GmbH ♦ Rehhecke 79 ♦ 40885 Ratingen ♦ Germany

Telephone: 02102 / 935 - 0

Fax: 02102 / 935 - 111

E - mail: info@mc-techgroup.com

www.mc-techgroup.com

1 GENERAL INFORMATION

The product described in this manual has been built and tested in our production facility.

All M&C products are packed to be shipped safely. To ensure the safe operation and to maintain the safe condition, all instructions and regulations stated in this manual need to be followed. This manual includes all information regarding proper transportation, storage, installation, operation and maintenance of this product by qualified personnel.

Please follow all instructions and warnings closely.

Please read this manual carefully before commissioning and operating the device. If you have any questions regarding the product or the application, please don't hesitate to contact M&C or your M&C authorized distributor.

2 DECLARATION OF CONFORMITY



The product described in this operating manual complies with the following EU directives:

EMC-Instruction

The requirements of the EU directive 2014/30/EU "Electromagnetic compatibility" are met.

RoHS Directive

The requirements of the RoHS2 ('Restriction of Hazardous Substances 2') directive 2011/65/EU and its annexes are met.

Low Voltage Directive

The requirement of the EU directive 2014/35/EU "Low Voltage Directive" are met.

The compliance with this EU directive has been examined according to DIN EN 61010.

Declaration of conformity

The EU Declaration of conformity can be downloaded from the **M&C** homepage or directly requested from **M&C**.



3 SAFETY INSTRUCTIONS

Follow these safety directions and instructions regarding installation, commissioning and operation of the device:

Read this manual before commissioning and operating the product. Make sure to follow all safety instructions.

Installation and commissioning of electrical devices must be carried out only by qualified skilled personnel in compliance with the current regulations.

The installation and commissioning of the device must conform to the requirements of VDE 0100 'Regulations on the Installation of Power Circuits with Nominal Voltages below 1000 V' and must be in compliance with all relevant regulations and standards.

Make sure to compare the supply voltage with the specified voltage on the product label before connecting the device.

Protection against damage caused by high voltages:

Disconnect the power supply before opening the device for access. Make sure that all external power supplies are disconnected.

Operate the device only in the permitted temperature and pressure ranges. For details please refer to the technical data sheet or manual.

Install the device only in protected areas, sheltered from rain and moisture. The product should not be exposed to the elements.

This device is NOT certified to be installed or operated in explosive hazardous areas.

Installation, maintenance, inspections and any repairs of the devices must be carried out only by qualified skilled personnel in compliance with the current regulations.

3.1 INTENDED USE

The CSS-M/W gas conditioning unit is intended for use in general purpose areas (non-hazardous environments). The CSS-M/W can only be operated in compliance with the information in chapter 8 Technical Data. You must meet the requirements of the ambient temperature and pressure characteristics in particular.

Do not use this product for any other purpose. Improper use and handling can create hazards and cause damage. For more information, please refer to the safety information in this instruction manual.



4 WARRANTY

In case of a device failure, please contact immediately M&C or your M&C authorized distributor. We have a warranty period of 12 months from the delivery date. The warranty covers only appropriately used products and does not cover the consumable parts. Please find the complete warranty conditions in our terms and conditions.

The warranty includes a free-of-charge repair in our production facility or the free replacement of the device. If you return a device to M&C, please be sure that it is properly packaged and shipped with protective packaging. The repaired or replaced device will be shipped free of delivery charges to the point of use.

5 USED TERMS AND SIGNAL INDICATIONS



Danger

DANGER indicates a hazardous situation which, if not avoided, will result in death or serious injury.



Warning

WARNING indicates a hazardous situation which, if not avoided, could result in death or serious injury.



Caution

CAUTION indicates a hazardous situation which, if not avoided, could result in minor or moderate injury.

Attention

ATTENTION is used to address practices not related to physical injury.



Note

These are important information about the product or parts of the operating manual which require user's attention.

Qualified Personnel

'Qualified personnel' are experts who are familiar with the installation, mounting, commissioning and operation of these types of products.



High voltages!
Protect yourself and others against damage which might be caused by high voltages.



Toxic!
Acute toxicity (oral, dermal, inhalation)! Toxic when in contact with skin, swallowed or inhaled.



Corrosive!
These substances destroy living tissue and equipment upon contact. Do not breathe vapors; avoid contact with skin and eyes.



Contains gas under pressure. Do not open container!
Check pressure before opening container, and adjust pressure to atmospheric pressure.



Hot surface!
Contact may cause burn! Do not touch!



Caution, risk of being crushed due to rotating parts.
Do not open the device. Use personal protective equipment (PPE).



Wear protective gloves!
Working with chemicals, sharp objects or extremely high temperatures requires wearing protective gloves.



Wear safety glasses!
Protect your eyes while working with chemicals or sharp objects. Wear safety glasses to avoid getting something in your eyes.



Wear protective clothes!
Working with chemicals, sharp objects or extremely high temperatures requires wearing protective clothes.



Use foot protection



Use safety helmet and full protective goggles

6 INTRODUCTION

The gas conditioning unit **CSS-M/W** for wall mounting is a completely pre-assembled compact gas conditioning system working continuously and delivering a sample gas quantity of max. 70 NI/h.

The entire gas conditioning unit is housed in a compact and robust steel sheet case which ensures that the gas analyzers can be carried out quickly, safely and with a minimum amount of maintenance.

The gas conditioning unit **CSS-M/W** for wall mounting must not be used for sampling of explosive gas/air or gas/oxygen mixtures, for sampling of combustible gases which may result in an explosive mixture in combination with air or oxygen nor in explosive atmospheres and hazardous areas.

7 APPLICATION

The gas conditioning unit **CSS-M/W** for wall mounting has been developed for continuous operation.

The components integrated in the system **CSS-M/W** are intended for "standard use".

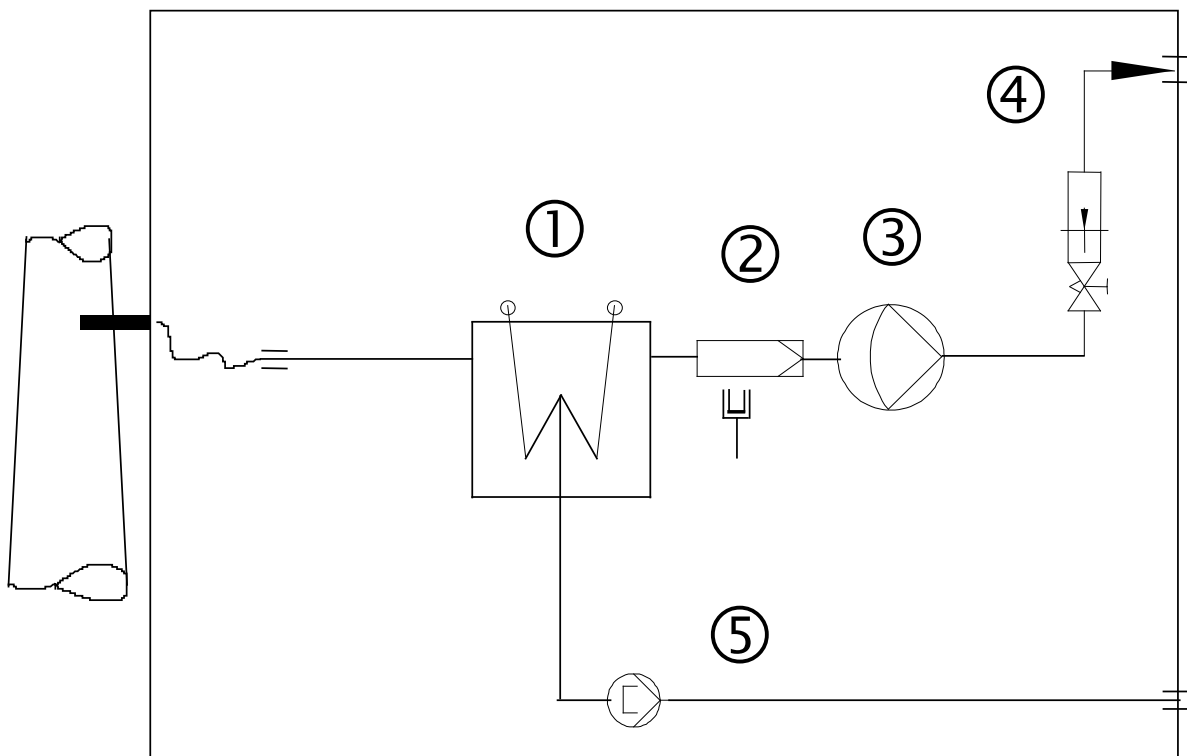

Figure 1 Scheme of gas flow

- ① Gas cooler **ECP**
- ② Front panel filter **FPF-2-0,3GF**, 0.3 µm porosity with integrated liquid alarm
- ③ Sample gas pump **N3 KPE**
- ④ Flowmeter **FM40**
- ⑤ Peristaltic pump **SR25.2** for continuous automatic condensate removal

8 TECHNICAL DATA

Gas Conditioning Unit Type	CSS-M/W
Sample outlet dew point	Range of adjustment: +2 to +15 °C [35.6 to 59 °F], factory setting: +5 °C [41 °F]
Dew point stability	At constant conditions $\pm 0.1\text{ °C}$ [$\pm 0.18\text{ °F}</math>]$
Sample inlet temperature	**Max. 80 °C [176 °F]
Gas inlet water vapor saturation	**Max. 50 °C [122 °F]
Gas flow rate	**Max. 70 NI/h
Ambient temperature	**+10 to +45 °C [50 to 113 °F]
Air humidity	$\leq 75\%$ year's average, rare and slight dewing of $\leq 95\%$ on 30 days per year admissible
Storage temperature	-25 to +65 °C [-13 to +149 °F]
Pressure	0.7 bar to 1.4 bar abs.*
Total cooling capacity	Max. 40 kJ/h
Number of gas inlets	1
Number of gas outlets	1*
Number of condensate outlets	1
Sample gas connections	Tube connection 4/6 mm
Material medium-touched parts	Glass, PVDF, PVC, Novoprene, Viton®, PPH
Ready for operation	Approx. 10 min
Mains power supply	230 V 50 Hz $\pm 10\%$ <i>or</i> 115 V 60 Hz $\pm 10\%$
Power consumption	Max. 240 VA
Fuse protection	4 A, time-lag, 5 x 20 mm
Electrical mains supply	Mains cable 3 x 1 mm ² , signal cable 3 x 0.5 mm ² , 3 m [$\approx 9.84\text{ ft}$] length
Status alarm, 1 change over contact, potential free	Contact rating 250 V AC, 2 A, collective alarm for gas flow, liquid and cooler temperature
Case protection	IP20 EN 60529
Housing version	Sheet steel case, lacquered, RAL 7035
Case dimensions (H x W x D)	177 x 263 x 372.5 mm [$\approx 6.97\text{''} \times 10.4\text{''} \times 14.7\text{''}$]
Weight	Approx. 11 kg [$\approx 24.3\text{ lbs}$]

PVDF=Polyvinylidene fluoride

PVC=Polyvinyl chloride

FPM=Fluor caoutchouc

PPH=Polypropylene hard

Specifications for components see appendix

* Standard

** Maximum values in technical data must be rated in consideration of total cooling capacity at 25 °C [77 °F] ambient temperature and an outlet dew point of 5 °C [41 °F].

Please note: NI/h and NI/min refer to the German standard DIN 1343 and are based on these standard conditions: 0 °C [32 °F], 1013 mbar.

9 DESCRIPTION

Figure 2 shows the dimensions and construction of the **CSS-M/W**.

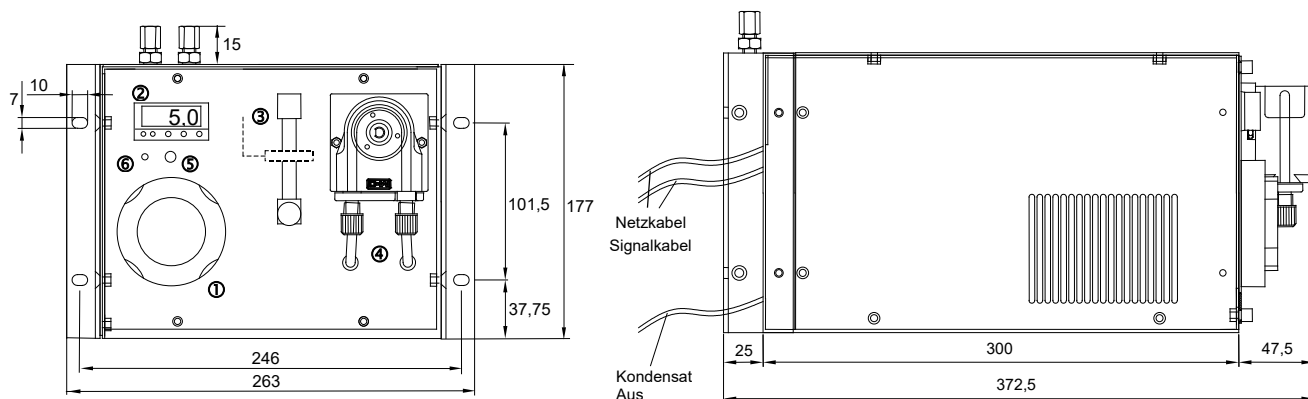

Figure 2 Dimensions CSS-M/W

- ① Fine filter **FPF-2-0,3GF**
- ② Electronic controller
- ③ Flow meter **FM40** with sample gas outlet
- ④ Peristaltic pump **SR25.2** with condensate outlet
- ⑤ Pump switch
- ⑥ LED indication condensate alarm red
- ⑦ Sample gas inlet

All components of the gas conditioning unit are mounted in a compact sheet steel case. Filter and peristaltic pump are placed into the front panel and thus assure a very easy maintenance.

The minimum flow rate is determined by the sample gas pump (see also chapter 15). If the required minimum total flow rate of 30 NI/h is not reached, excessive overpressure can lead to premature destruction of the pump diaphragm.

The gas cooler is equipped with a heat exchanger made of Duran glass.

The fine filter **FPF-2-0,3GF** (0.3 µm filter porosity) ⑦ installed in front of the sample gas pump **N3 KPE** ensures the necessary removal of solid particles.

The device has a temperature alarm contact. An alarm is triggered with factory configuration (gas outlet dew point: 5 °C, alarm window: 3 °C, alarm hysteresis: 1 °C) within the limits < +1.5 °C (under temperature) and > +8.5 °C (over temperature). See also chapter 18, Figure 11.

When the sample gas pump is switched on (switch set to "Pump on" and illuminated green), the temperature alarm contact automatically switches the sample gas pump on and off.

The condensate occurred is removed continuously via the peristaltic pump type **SR25.2**. The DN4/6 mm hose connections for the condensate and sample gas outlet are located on the front panel, the DN4/6 mm sample gas inlet is located on the back side on the case.

The ventilation grids in the sidewalls ensure that the equipment is sufficiently ventilated.

A liquid alarm sensor is integrated in the filter **FPF-2-0,3GF** to protect the downward analyzers against liquid irruptions and to increase the operating safety of the whole system. In case of liquid inrush, the internal electronic of the sample gas pump is automatically switched off.

10 RECEIPT OF MARCHENDISE AND STORAGE

The gas sampling system **CSS-M/W** is a completely pre-installed unit. The scope of delivery includes furthermore:

- 25 x Filter elements (1 package)
- 1 x Connection cable
- 1 x Instruction Manual

Please take the **CSS-M/W** and possible special accessories carefully out of the packaging material immediately after arrival, and compare the goods with the items listed on the delivery note;

Check the goods for any damage caused during delivery and, if necessary, notify your transport insurance company without delay of any damage discovered.



Note

The gas conditioning system should be stored in a protected frost-free area!

11 INSTALLATION INSTRUCTIONS



Note

In order to ensure that the case is safe and stable when being used, it should be placed on a horizontal surface free from vibrations. Only then, the perfect functioning of the separation and drainage procedures of the condensate inside the heat exchanger of the cooler will only be guaranteed.

The gas conditioning system should be kept away from heat sources and be freely ventilated in order to prevent an accumulation of heat.

When the equipment is being used outside, ample protection against the effects of direct sunlight and dampness must be provided. In winter, the equipment must only be used in frost-free areas; pay attention to the type of the equipment protection.

Please avoid temperature variations, strong airflow as well as aggressive atmospheres at the instalment location.

In order to guarantee the operational safety of the gas conditioning system and the downstream analyzers, and to avoid false alarms, the gas conditioning unit should not be used at temperatures other than those specified. Furthermore, it must be protected against dust deposits and penetrating dust.

It is of great importance that the analyzers connected downstream are used at temperatures well above the specified gas outlet dew point of +5 °C [+41 °F]. This prevents the gas in the connector lines to the analyzers from subsequent condensing.

Unheated gas sample lines must be installed with slope up to the cooler. In this case, a preliminary condensate separation is not required.

12 HOSE CONNECTIONS

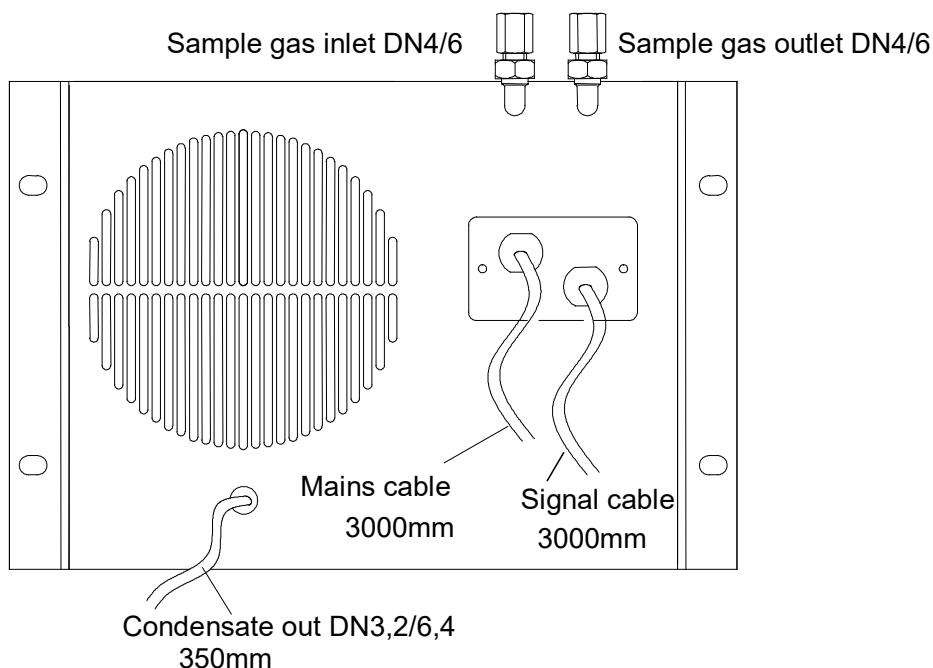

Figure 3 Hose connections CSS-M/W



Note

Do not mix up the hose connections; the connections are marked according to Figure 3.

After having connected all lines, please check the seals.

All tube connections are DN4/6 mm sealing ring threaded hose couplings out of PVDF/PPH as standard. They are suitable for gas inlet temperatures of maximum 80 °C [176 °F] (see chapter 8).

Follow these steps to mount the sample gas and condensate tubes:

1. Remove the union nut from the sealing ring couplings by turning it anti-clockwise. Be sure to remove the union nut carefully from the fitting. There is a loose clamp ring inside the union nut.
2. Place the union nut over the connecting tube.
3. Push the sealing ring over the connecting tube with the thicker bulge facing the nut.
4. Place the tube over the nipple on the thread.



Note

The tightness of the connections can only be guaranteed if the connecting hose has a straight edge (use a hose cutter).

5. Hand-tighten the nut. The tube is now slip-proof and pressure-tight mounted to the hose connection fitting.
6. The tubes are to be removed in the reverse order.

**Warning**

Aggressive condensate is possible.



Chemical burns caused by aggressive media possible!



Wear protective gloves and protective glasses!

Wear proper protective clothing!

13 ELECTRICAL CONNECTIONS

**Warning**

False supply voltage can damage the equipment. When connecting the equipment, please ensure that the supply voltage is identical with the information provided on the model type plate!

**Note**

For the assembly of power installations with rated voltages up to 1000 V, the requirements of VDE 0100 and relevant standards and specifications must be observed!

The main circuit is equipped with a fuse corresponding to the nominal current (over current protection); for electrical details see technical data.

The gas conditioning unit **CSS-M/W** is available with either 230 V/50 Hz or 115 V/60 Hz (for circuit diagram see Appendix). A 4 A fuse is used on all models as fuse protection. The fuse is located on the electronic board inside the steel sheet case.

The electrical connection is made via the mains cable of 3 x 1 mm² on the back side of the case.

Brown	= L
Blue	= N
Green/yellow	= PE

Connection of the signal lines:

The signal cables, 3 m [≈ 9.84 ft] long, 3 x 0,5 mm² are numbered from 1 – 3 (Status signals of the condensate controller, the cooling temperature and the optional flow alarm sensor).

1	= NC
2	= MC
3	= NO

Please install the signal lines separated from the power supply lines. The contact rating for the alarm contact is max. 250 V AC 2 A.

14 PREPARATIONS FOR COMMISSIONING

Before initial startup, all plant- and process-specific safety measures must be observed. It is mandatory for the operator to complete the enclosed risk assessment of the product.

The gas exposure risk must be assessed by the operator with regard to the hazards posed by process and calibration gas and the setup at the installation site (e.g. tubing, system cabinet/container/plant). If the risk assessment reveals increased exposure hazards, further measures are required.

A visible label must be attached to the installation site in accordance with the risk assessment provided by the operator.

15 STARTING UP

Before starting the gas conditioning system, pay attention to the site-oriented and process-oriented precautions. Please check once again that the operating voltage (see type plate) corresponds to the supply voltage!



Note

Before connecting the equipment to the mains voltage, the main switch must be in position "0".

The following steps have to be done before starting up for the first time:

1. Place the cold appliance plug, which is delivered with the mains supply cable, into the cold appliance plug socket;
2. Connect the mains plug to the mains;
3. Turn the main switch to the position "I".

After the starting time (LED K1 on the controller is on), the gas conditioning system is ready for use, and the sample gas pump is switched on, if the key is activated (green light is on).

The sample gas must not be fed before the starting time of the sample gas cooler is finished, i.e. if the sample gas outlet temperature does not exceed the limits adjusted at works (LED K1 on the controller is on).



Note

The request for a maximum pressure load of the sample gas pump *N3 KPE* of 1.4 bar abs. results in the following minimal gas flow rate:
N3 KPE min. 30 NI/h air.

Premature damage can be caused to the pump membrane due to excess pressure if less than the minimal total amount of flow is extracted.

In case of long-term measurements with a high level of dust, it is necessary to utilise a suitable sample gas probe in order to protect the sample leads from clogging-up.



15.1 COOLER REGULATION

	Indication	LED K1	LED K2
After starting up	> 8 °C [46.4 °F] (Ambient temp.)	Off (Status alarm and pump off)	Yellow light is permanently on (cooling)
After approx. 10 min.	≤ 7.5 °C [45.5 °F]	Yellow light is on. In case no condensate alarm is given and the pump switch is activated (green light is on), the pump will be switched on. Sample gas is lifted.	Yellow light is permanently on (cooling)
Normal operation	5 °C [41 °F]	Yellow light is on	Yellow light is flashing (cooler control)

15.2 PUMP SWITCH

In the past time, it happened repeatedly that the pump switch of the gas conditioning system CSS-M/W failed. For that reason, we changed the switch in 06/2007 into a key button. The effect is that the switch status of the pump in case of a voltage loss does not exist anymore.

In order to keep the switch status, there is a jumper JP1 on the board by which you can determine whether the pump shall restart automatically after a voltage loss or not.

- With the bridge 2-3 (on), the pump restarts automatically.
- With the bridge 1-2 (off), the pump does not restart again.

When delivered, the bridge is made between 1-2 (off), i.e. the pump does not restart after a voltage loss.

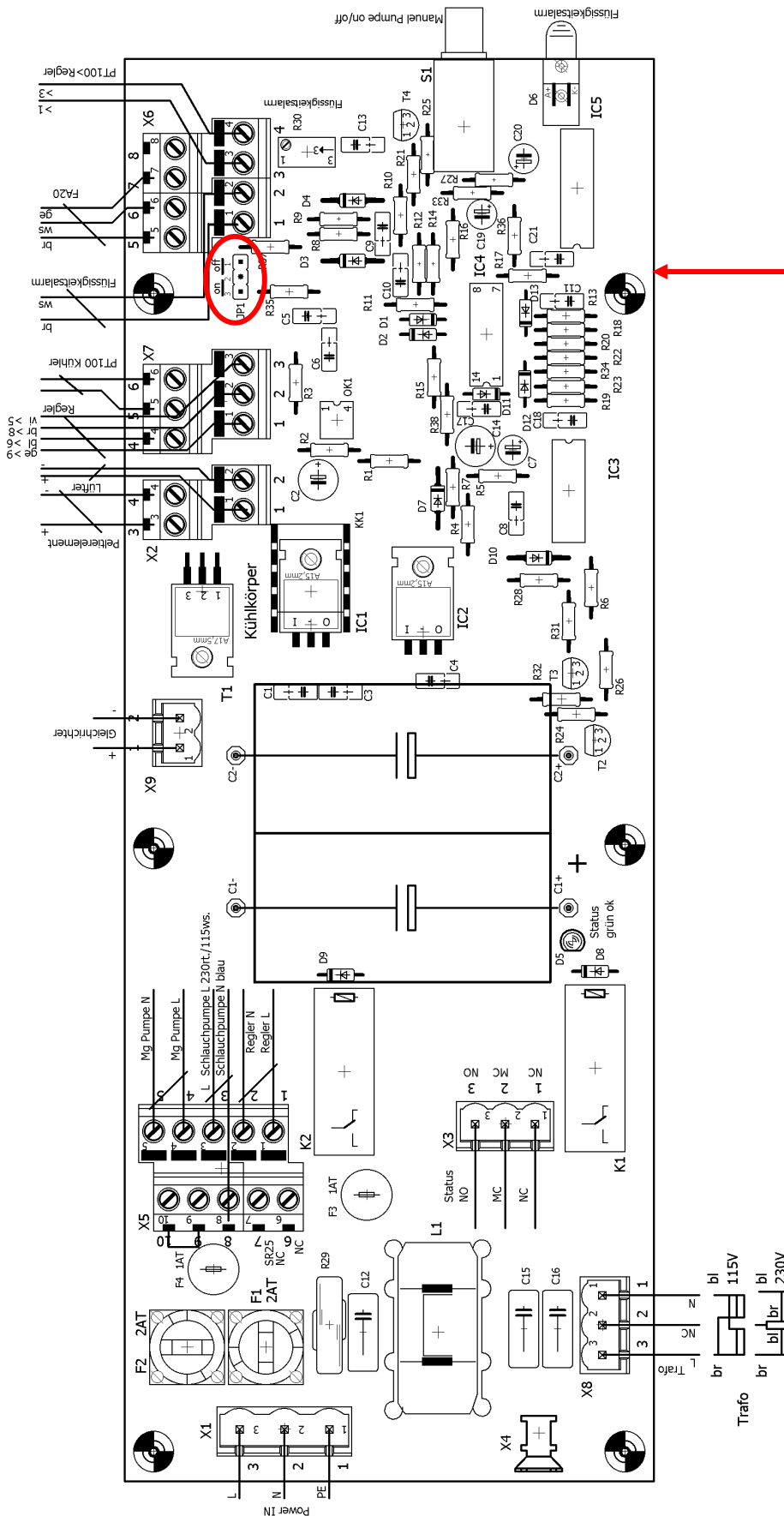

Figure 4 Electronic board CSS-M/W

16 CLOSING DOWN



Note

The location for the gas conditioning unit must remain frost-free, even if the unit has been switched off.

There are no special regulations to be observed if the gas conditioning unit **CSS-M/W** is to be closed down for a short period of time.

In case of a long-term closing down, for example after a series of measurements has been completed, it is recommended to purge the gas conditioning system with ambient air or inert gas. Under normal conditions, the equipment needs only to be purged for 3 to 5 minutes. Condensate residues should also be removed from the system.



Warning

Aggressive condensate is possible.



Chemical burns caused by aggressive media possible!

When disassembling, repairing or cleaning, wear safety glasses and proper protective clothing!

17 MAINTENANCE

Before carrying out any maintenance work, the specific safety instructions referring to the instalment and the process must be observed!



Warning

Dangerous voltage. Before any maintenance work is carried out on the gas conditioning system, put the main switch of the instrument into position "0" and tear the mains plug off!



The frequency of the maintenance work depends on the operational process and can therefore only be determined in each individual case.

All parts which require maintenance work are easily accessible and are installed on the front side of the gas conditioning unit **CSS-M/W**. Only for any work on the gas sample pump, the case has to be opened:

- Replace the filter element of the fine filter **FPF-2-0,3 GF** in case the flow rate is too low or after visible control.

**Note**

In order to protect downstream analyzers, the wet filter element must always be replaced in the event of a condensate ingress.

- The hose of the condensate pump **SR25.2** should be checked every six months and, if necessary, replaced (see chapter 17.3.1).
- The diaphragm of the sample gas pump **N3 KPE** should be checked every six months and, if necessary, replaced.

17.1 REPLACEMENT OF THE FILTER ELEMENT AND THE O-RING

**Note**

In any case you open the filter, the filter element must be changed.

For changing the filter element and the O-ring:

1. Disconnect the mains voltage.
2. Unscrew the filter housing cover.
3. Exchange the filter element and/or O-ring. Pay attention to the correct insertion of the filter element and the O-ring (the structural surface of the filter element must show to the front!).
4. Screw down the filter housing cover again.

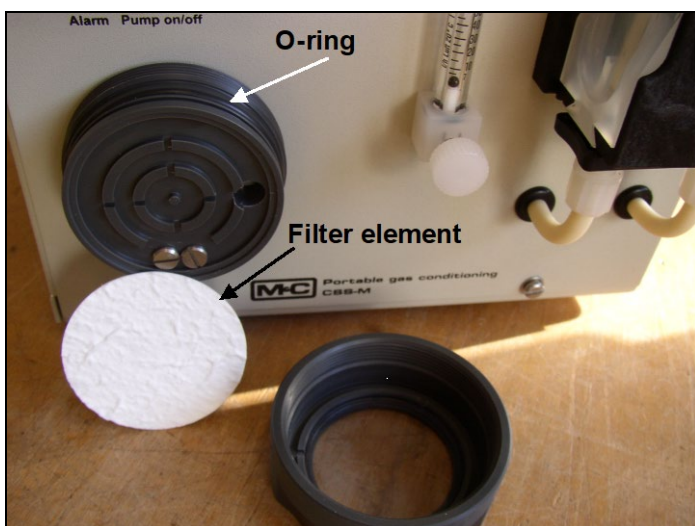

Figure 5 Replacement of the filter element and the O-ring

17.2 DISMOUNTING THE SAMPLE GAS PUMP FOR EXAMINATION OR MAINTENANCE

For dismounting the sample gas pump **N3 KPE**:



Warning

Dangerous voltage. Before any maintenance work is carried out on the gas conditioning system, disconnect the unit from the mains!



1. Disconnect the gas conditioning system from the mains voltage.
2. Unscrew the front panel and put it beside without detaching the piping and the wiring.
3. Loosen the 4 fastening screws of the mounting angle on which the pump is mounted.
4. Pull out the pump with mounting angle.
5. Examination and maintenance of the pump **N3 KPE**.
6. After examination and maintenance screw down the mounting angle again and mount the front panel.

17.3 MAINTENANCE OF THE INTEGRATED PERISTALTIC PUMP TYPE SR25.2

Before starting any maintenance work, make sure that any work done on the device is in compliance with all relevant regulations and standards.



Warning

Inhalation hazard possible, if using toxic or asphyxiant gases!



Purge peristaltic pump with inert gas or air before opening! If the pump is used for toxic gas or asphyxiant (oxygen-displacing) gas, it needs to be purged with inert gas or air before opening. Follow closely all relevant occupational safety regulations during operation.



Warning

Disconnect power supply before opening the device for access.
Make sure that all external power supplies are disconnected.



Aggressive condensate possible!

Media residues in tubing!
Chemical burns caused by aggressive media possible!



Wear protective gloves and protective glasses!



Wear proper protective clothing!



Peristaltic pump is under pressure! Do not open housing!

A peristaltic pump might be part of a system, which is under pressure. Check pressure before opening peristaltic pump, and adjust pressure to atmospheric pressure.

Flexible tube, conveying belt, contact pulleys and contact springs are the only parts of the pump subject to wear. They are simple to change.



Note

If you send back the peristaltic pump to the M&C service for repair, please let us know what kind of condensate has been pumped. Before sending the pump back clean all parts from dangerous or highly aggressive contaminants.

17.3.1 MOUNTING INSTRUCTIONS FOR PERISTALTIC PUMP

Make sure to mount the pump to the front of the cooler with a minimum distance of 3.5 mm [≈ 0.138 "] and a maximum distance of 5.5 mm [≈ 0.216 "] between the pump motor and the front panel. The minimum distance avoids damage to the pump motor and the maximum distance prevents the motor shaft from getting loose.

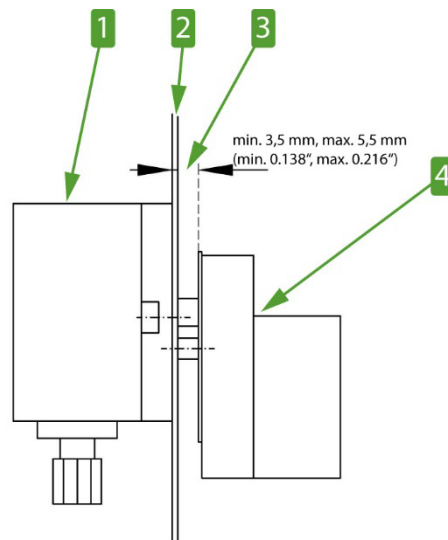

- 1 Pump head (outside the device housing)
- 2 Device front panel
- 3 Recommended mounting distance
- 4 Pump motor (inside the device housing)

Figure 6 SR25.2: Mounting distance between front panel and pump motor



Note

For detailed mounting instructions, see the instruction manual for the peristaltic pump series SR[®]. The manual is available on our website www.mc-techgroup.com.

17.3.2 CHANGING THE PUMP TUBING

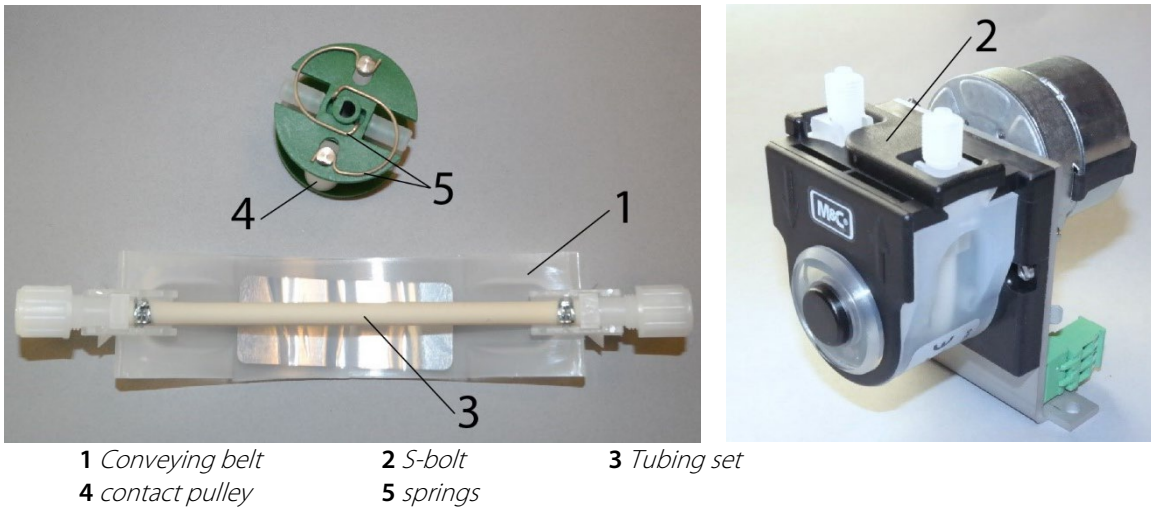

Figure 7 Changing the pump tubing

For changing the pump tubing please proceed as follows:

1. Unplug the pump from the mains voltage. The device needs to be voltage free.
2. Open tube connections at the pump;
3. Press conveying belt ① at the recessed grips and turn S-bolt ② clockwise up to limit stop;
4. Take away conveying belt ① and remove the old tubing set ③ from the guides by pulling on the tube connectors;
5. Press the two contact pulleys ④ and check whether the spring pressure is still sufficient, if not, the contact springs have to be changed (see chapter 17.3.3);
6. Put the new tubing set ③ with the tube connectors into the guides of the conveying belt ① ;



Warning

Only the usage of the original tubing set guarantees a proper functionality.
Never lubricate the tube.

Before mounting the pump check all parts for contaminations and clean if necessary.

7. Put the conveying belt ① with the new tubing ③ into the dovetail guide of the pump body;
8. Press conveying belt at the recessed grips and simultaneously turn the S-bolt ② anticlockwise until it snaps;
9. Switch on pump.

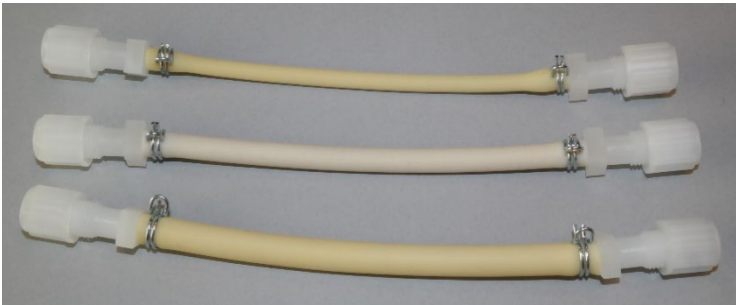

Figure 8 Different pump tube sizes

17.3.3 CHANGING CONTACT PULLEYS AND SPRINGS



Note

While mounting, make sure that the center of rotation and the driver are aligned. Use genuine spare parts only!

Follow these instructions to change the contact pulley and springs:

- 1. Disconnect the peristaltic pump from power supply.
- 2. Unscrew nuts of the pump head (wrench size 5.5) ①.

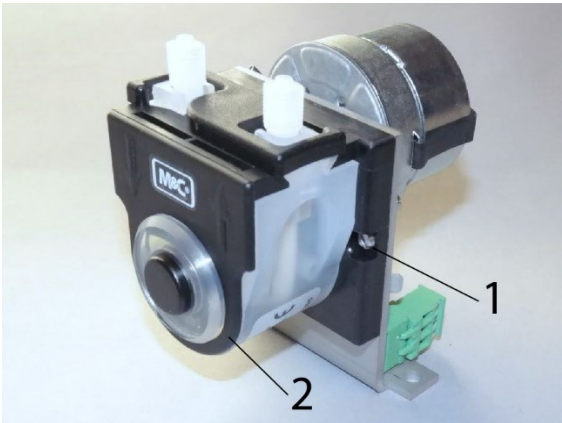

1 Pump head nuts

2 Pump head

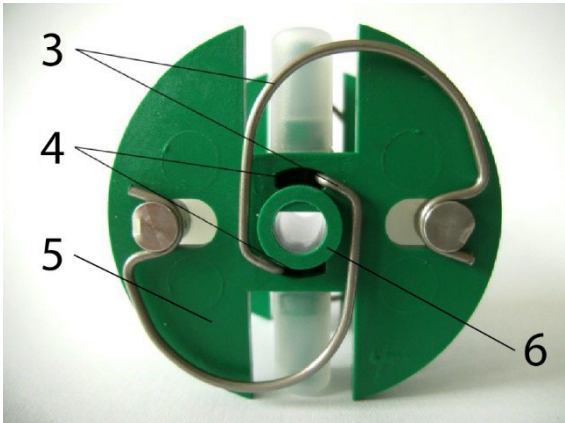

3 Springs

4 Groove

5 Driver (roll carrier)

6 Collar of the shaft bore

Figure 9 Disassembly of pump head and driver

- 3. Remove the pump head ② from the motor shaft.
- 4. Now the driver can be removed from the pump head and is ready for maintenance.
- 5. The removal of the springs (4 pcs.) ③ away from the driver is easily possible without the aid of any tools. For this take spring out of the groove ④ near to the shaft bore.

6. Dismount roller axes and change contact pulleys. Take care that axes are not worn out by the springs and have damaged the dent at the axes front end. In case of abrasion the axes have to be changed (see Figure 10).

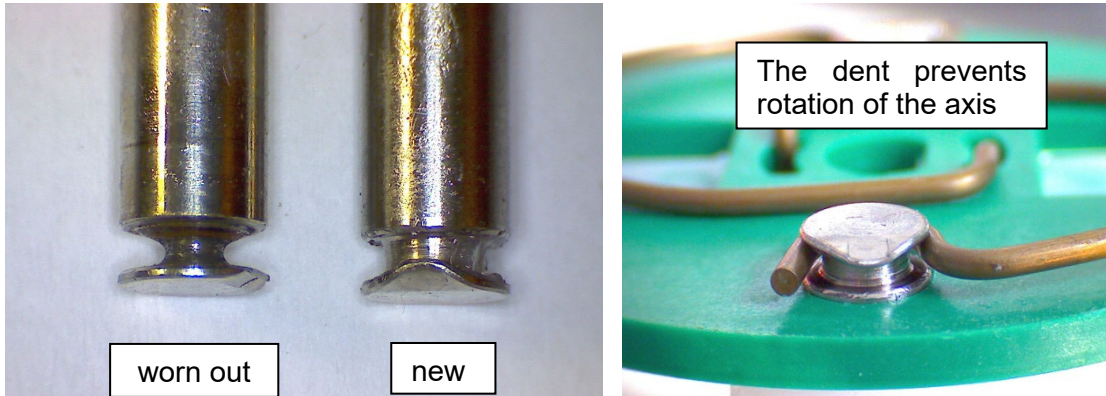

Figure 10 Check of axes and rolls



Note

The springs may come in different colorings. This is not a quality impairment. Make sure to use the right spring strength. This can be identified by the spring wire diameter.

The 'standard version for Novoprene pump tubing' (Part No. 90P1010) has a diameter of 1.1 mm and the 'reinforced version for FKM-, Acidflex- or Masterflex-tubing' (Part No. 90P1015) has a diameter of 1.2 mm.



Note

Two different types of springs are mounted inside the driver (right and left springs) for the first delivery.

When spare springs are ordered, for simplified storage, only one type will be delivered (right spring) which can be used for all four springs and will replace without any problems the initial springs. The replacement springs guarantee full functionality when all four springs are replaced.

7. Make sure that contact pulleys move easily on the axis. After remounting the axis with contact pulley into the driver the spring has to be mounted as shown as in Figure 10. Please pay attention to the alignment of the dent.

17.3.4 REASSEMBLY OF THE DRIVER

Reassemble the driver in reverse order:

1. Insert the roll carrier back into the pump head
2. Push the pump head with the roll carrier onto the motor shaft ②
3. Tighten the nuts of the pump head fastening (SW 5.5) ①.



Note

While mounting, make sure that the center of rotation and the roll carrier (driver) are aligned.

Make sure that the collar of the shaft bore (see Figure 9) faces towards the front of the pump head while mounting the roll carrier.

Use genuine spare parts only!

17.3.5 CLEANING THE PUMP HEAD

When changing flexible tube or other parts, inspect all parts for dirt before assembling the pump head and clean them if necessary.

We recommend to clean the parts with a dry cloth. Solvent should not be used, because it can damage the plastics and synthetic rubber parts. Use oil-free compressed air to clean the parts if available.



Aggressive condensate possible!

Media residues in tubing!

Chemical burns caused by aggressive media possible!



Wear protective gloves and protective glasses!



Wear proper protective clothing!

17.3.6 REPAIR INFORMATION FOR INTEGRATED PERISTALTIC PUMP TYPE SR25.2



Note

When sending the peristaltic pump to M&C customer service for repair, please indicate the type of medium pumped. Before shipping the pump, please remove hazardous or aggressive contaminations from all parts of the pump!

18 OPERATING OF THE BUILT-IN ELECTRONIC TEMPERATURE CONTROLLER

New electronic temperature controllers were installed in the housing of the conditioning unit CSS-M/W effective April 2022 and June 2023.

All built-in temperature controllers are factory set to the following values: Gas outlet dew point 5 °C [41 °F], alarm window: 3 °C [5.4 °F], alarm hysteresis: 1 °C [1.8 °F].

Figure 11 shows the hysteresis behaviour of the temperature alarm at factory settings. The alarm of the temperature controller is activated (Alarm ON) and deactivated (Alarm OFF) depending on the temperature, following the hysteresis.

When the cooler is switched on, the temperature is cooled down starting from the ambient temperature, which means that the temperature alarm is activated: Alarm ON. Figure 11 shows that the alarm remains active until the temperature of 7.5 °C [45.5 °F] is reached. The alarm follows the hysteresis and is set to Alarm OFF at 7.5 °C [45.5 °F]. If the temperature remains within the range of 1.5 to 8.5 °C [34.7 to 47.3 °F], the alarm will stay at Alarm OFF. If the temperature changes beyond these limits, the temperature controller follows the hysteresis and sets the alarm back to Alarm ON at a temperature below 1.5 °C [34.7 °F] or above 8.5 °C [47.3 °F].

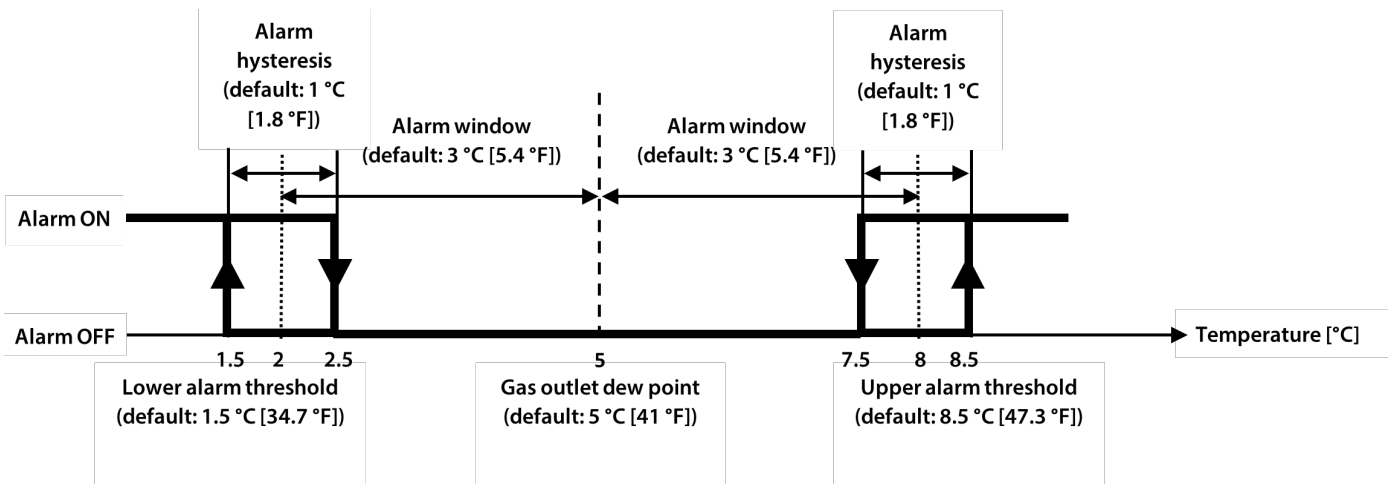

Figure 11 Hysteresis behavior of the temperature alarm at factory settings

18.1 TEMPERATURE CONTROLLER VERSION UNTIL MARCH 2022

During normal operation, the display of the temperature regulator shows the actual cooling temperature. Figure 12 shows the front view of the temperature controller.



Figure 12 Front view of the temperature controller version until 03.2022



18.1.1 CHANGING THE SET VALUE

For changing the set value, press the P-button < 2 s. The set value, adjusted at the factory to 5 °C [41 °F], is shown. With both arrow keys, the set value can be set upwards or downwards. However, this value should not be adjusted below +2 °C [35.6 °F], otherwise freezing up of the heat exchanger is possible. If the value is set above ambient temperature, the cooler will not work.

18.2 TEMPERATURE CONTROLLER VERSION STARTING APRIL 2022

In normal operation, the display of the temperature controller shows the current cooling temperature in the upper line. In the bottom line, the adjusted set point is displayed.



Figure 13 Front view of the temperature controller version starting 04.2022

18.2.1 CHANGING THE SET VALUE

Pressing the Δ or ∇ key once causes the set setpoint to start flashing in the bottom line. Now the setpoint can be increased or reduced using the Δ or ∇ keys. However, the value should not be set lower than +1 °C [33.8 °F], otherwise the heat exchanger is likely to freeze.

The change can be cancelled at any time with the \curvearrowright key. The change is only accepted with the Menu/OK key.

18.3 TEMPERATURE CONTROLLER VERSION STARTING JUNE 2023

In normal operation, the display shows the measured temperature (temperature view). The ESC key and the arrow keys (UP and DOWN) are disabled in this view. Figure 14 shows the front view of the temperature controller.



Figure 14 Front view of the temperature controller version starting 06.2023

While you tap on the OK key, the set setpoint value is displayed. The factory setting of the setpoint is "5.00". After releasing the key, the display immediately returns to the temperature view. The setpoint is only visible when the key is tapped.

18.3.1 CHANGING THE SET VALUE

The temperature controller needs to be unlocked, before changing the setpoint. To unlock the device, first press the OK key for about 3 seconds. The display changes to a flashing "000".

Then enter the PIN code "017" with the arrow keys and confirm the entry with OK. The display jumps back to the temperature view.

Now the temperature controller is unlocked. Again, press the OK key for about 3 seconds. The display changes to the setpoint view and the display is flashing.

While the display is flashing, the setpoint can be adjusted with the arrow keys. With OK the new setpoint is accepted. With ESC the current changes are discarded. In both cases, the display jumps back to the normal temperature display after pressing.



Note

If you hold the OK key too long, you will enter the configuration menu. This menu shows a "C", followed by two digits on the display. To return to the temperature view tap on the ESC key.

19 TROUBLE SHOOTING

The following table shows possible sources of errors and how to remove them (not applicable for the starting-up phase).

Display	Fault	Possible cause	Examination/Correction
None		No supply voltage;	Check the supply voltage according to the type plate; ok? Control whether the mains plug is put in correctly or whether the main switch is in position "1"; ok? Examine the fine fuses F1, F2 on the internal board; ok?
LED K1 is always on and temp. > 8 °C [46.4 °F]		Cooler alarm "Excess temperature"; cooler switches the sample gas pump automatically off; Ventilator does not function	Ambient temperature too high; ok? Free convection inside the gas conditioning unit upset ⇒ internal temperature too high; ok? Sample flow or dew point too high? Reduce flow. ok? Return the instrument for repair to M&C.
Temp. >2 °C [35.6 °F] and < 7.5°C [45.5 °F]	Cooler runs, sample flow is interrupted; Alarm-LED in front panel is red (see Figure 2) Pump defective	Diaphragm pump does not work; Pump is not switched on <u>Liquid alarm sensor:</u> Sensor turns sample gas pump automatically off;	Turn switch to position "on" (light is green) Ok? LED Liquid alarm is red. Liquid in the filter (Dry filter and liquid alarm sensor and check peristaltic pump, see below.) ok? Check the hoses for condensate draining; ok? Check pump hose (see chapter 17.3.1); ok? Check pump SR25.2 (see chapter 17.3); ok? Return instrument for repair to M&C.
	Pump works, but sample gas flow is interrupted;	<u>Flow meter:</u> Needle valve is shut. Sample probe or sample hose clogged or line squeezed;	Set the desired flow rate on the needle valve. Loosen the sample hose from the sample gas inlet of the gas conditioning unit (see chapter 12); Gas flow? Clean the clogged line or replace it; No gas flow?



Display	Fault	Possible cause	Examination/Correction
		Sample line to the analyzer clogged or squeezed; Pollution of the diaphragm pump;	Loosen the outlet hose on the analyzer side and check on the threaded hose coupling whether sample gas flows; Sample gas does not flow? Clean the clogged line or replace it; Sample gas flows? ok? Loosen the piping on the pump head and examine it (see chapter 17.2); ok? If necessary, clean the pump; Ok?
Temp. < 2 °C [35.6 °F]		Cooler switches the sample gas pump automatically off; Cooler defective;	Ambient temperature too low; ok? Return the instrument for repair to M&C.

20 PROPER DISPOSAL OF THE DEVICE

At the end of the life cycle of our products, it is important to take care of the appropriate disposal of obsolete electrical and non-electrical devices. To help protect our environment, please follow the rules and regulations of your country regarding recycling and waste management.

21 SPARE PART LIST

Wear, tear and replacement part requirements depend on specific operating conditions. The recommended quantities are based on experience and are not binding.

Gas Conditioning Unit Version CSS-M/W					
(C) Consumables, (R) Recommended Spare Parts and (S) Spare Parts					
Part No.	Description	C/R/S	Recommended quantity after operation of [years]		
			1	2	3
Fine filter FPF-2-0,3GF					
90F0160	Filter element type F-2-0,3GF, material: glass fiber, porosity: 0.3µm, 25 pcs./pack.	C	1	2	3
90F0167	O-ring FPF-2/54, material: Viton®.	R	1	1	1
Peristaltic pump SR25.2:					
90P1007	SR25 pump hose with threaded hose coupling of PVDF, DN 4/6 mm	C	1	2	4
Diaphragm pump type N3 KPE					
90P2100	Square cap type D3, 1/8" i for N3/N5 KPE/KP18, material: PVDF	S	-	-	1
90P2120	Diaphragm type S3, for N3/N5 KPE/KP18, Material: Viton®, PTFE coated	C	1	2	3
90P2111	Valve reed type V3 with O-ring type O3, for N3-N5, 1 pc, material: Viton® (2 pieces per pump required)	C	2	4	6
90P2105	Intermediate plate type Z3, for N3/N5 KPE/KP18, material: PVDF	S	-	-	1
Flow meter FM40:					
90A0015	Flow meter glass for FM40, measuring range 7-70 l/h air	S	-	1	1
90A0018	Viton® O-ring 9 for FM40 glass	R	2	4	6
Miscellaneous:					
90K6030	Fine fuse 4 A T, 5 x 20 mm for CSS...	R	5	5	5
Hose and threaded hose couplings:					
05V3215	Bulkhead union SV-PVDF DN 4/6	R	2	2	2
05V6600	Ferrule 4/6 PVDF s.a.	R	5	10	10
05V6605	Union nut M10-4/6 PVDF s.a.	R	5	10	10
01T1000	Viton tube NW 4/6 (m)	S	1	2	3
10T1000	Hose cutter	S	1	1	1

22 RISK ASSESSMENT

The risk assessment provided in this chapter is intended for all work activities on the product. The hazards can occur in the work steps of assembly, commissioning, maintenance, disassembly and in the event of a product fault. During normal operation, the product is protected by a system cabinet or appropriate covers.

Only qualified personnel is permitted to perform the work. The following minimum knowledge is required for the work:

- Employee instruction provided in process engineering
- Employee instruction provided in electrical engineering
- Detailed knowledge of the instruction manual and the applicable safety regulations

The product complies with the current regulations according to state-of-the-art science and technology. Nevertheless, not all sources of danger can be eliminated while observing technical protective measures. Therefore, the following risk assessment and the description of exposure hazards refer to the work steps mentioned above.

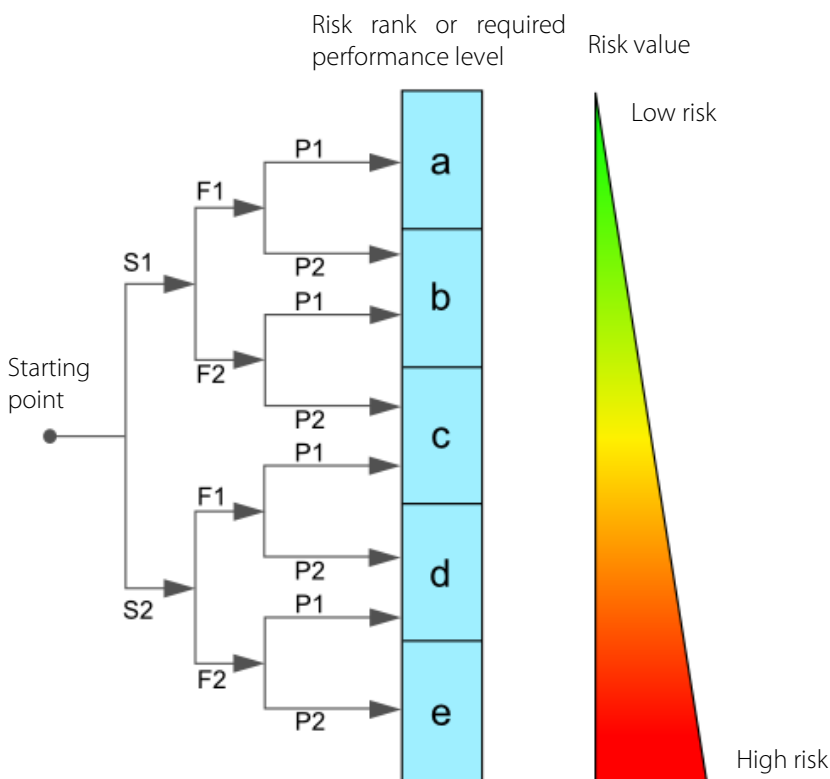

Severity of injury:

S1 = 1 = minor (reversible injury)

S2 = 2 = serious (irreversible injury, death)

Frequency and duration:

F1 = 1 = infrequent or short exposure to hazard

F2 = 2 = frequent (more than once per hour/shift)

Possibility of preventing or limiting the damage

P1 = 1 = possible

P2 = 2 = hardly possible

Figure 15 Overview risk assessment



Aggressive condensate possible

Risk rank group A

Chemical burns due to aggressive media possible!

This applies to all liquids in vessels and in the product.

In general, for electrical and mechanical work on the product, wear personal protective equipment (PPE) in accordance with the risk assessment.



Caution risk of being crushed by rotating parts

Risk rank - group A

The product contains rotating parts. Do not open covers until the device has been switched off.



Caution glass

Risk rank - group A

The product contains glass components. In general, for electrical and mechanical work on the product, wear personal protective equipment (PPE) in accordance with the risk assessment.



Caution hot surfaces

Risk rank group A

The temperature inside the product can be higher than $> 60\text{ }^{\circ}\text{C}$.

The hot parts are shielded by mechanical devices. Before opening the products, they must be disconnected from the power supply and a cooling time of more than > 20 minutes must be observed. In general, for electrical and mechanical work on the product, wear personal protective equipment (PPE) in accordance with the risk assessment.



Caution electric shock

Risk rank group C

When installing high-power systems with nominal voltages of up to 1000 V, the requirements of VDE 0100 and their relevant standards and regulations must be observed!

This also applies to any connected alarm and control circuits. Before opening the products, they must always be disconnected from the power supply.



Gas hazard

Risk rank group A-B-C

The hazard potential mainly depends on the gas to be extracted.

If toxic gases, oxygen displacing or explosive gases are conveyed with the product, an additional risk assessment by the operator is mandatory.

In principle, the gas paths must be purged with inert gas or air before opening the gas-carrying parts.

The escape of potentially harmful gas from the open process connections must be prevented.

The relevant safety regulations must be observed for the media to be conveyed. If necessary, flush the gas-carrying parts with a suitable inert gas. In the event of a gas leakage, the product may only be opened with suitable PPE or with a monitoring system. Furthermore, the work safety regulations of the operator must be observed.



Caution crushing hazard

Risk rank group A

The work must be performed by trained personnel only.

This applies to products weighing less than < 40 kg [≈ 88.2 lbs]:

The product can be transported by 1 to 2 person(s). The instructions for appropriate personal protective equipment (PPE) must be observed.

The weight specifications are contained in the technical data of this product. Furthermore, the work safety regulations of the operator must be observed.

23 APPENDIX

- Circuit diagram **CSS-M/W**



For further product documentation, please see our website:

www.mc-techgroup.com

- Instruction manual peristaltic pump **SR25.2**
- Instruction manual diaphragm pump **series N**
- Data sheet flowmeter **FM 40**
- Data sheet liquid alarm sensor **LA1**

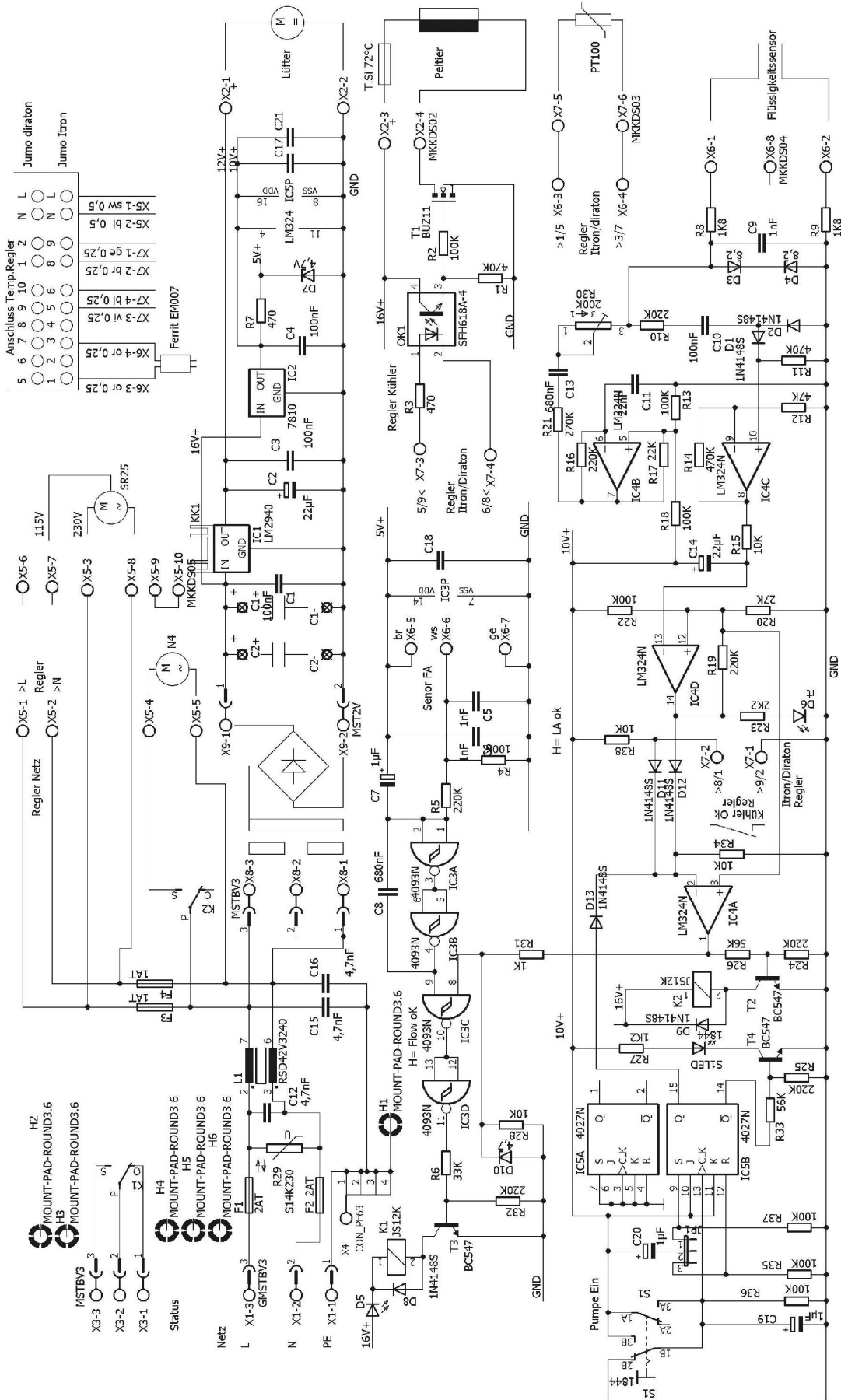

Figure 16 Circuit diagram CSS-M/W