

In-situ Laser Analyzer

Pneumatic Supply Unit for Purge Gas

ILA SU-G10 EX

Instruction Manual
Version 1.00.01



Dear customer,

Thank you for buying our product. In this instruction manual you will find all necessary information about this M&C product. The information in the instruction manual is fast and easy to find, so you can start using your M&C product right after you have read the manual.

If you have any questions regarding the product or the application, please don't hesitate to contact M&C or your M&C authorized distributor. You will find all the addresses in the appendix of this manual.

For additional information about our products and our company, please go to M&C's website www.mc-techgroup.com. There you will find the data sheets and manuals of all our products in German and English.

This Instruction Manual does not claim completeness and may be subject to technical modifications.

© 02/2026 M&C TechGroup Germany GmbH. Reproduction of this document or its content is not allowed without permission from M&C.

With the release of this version all older manual versions will no longer be valid. The German instruction manual is the original instruction manual. In case of arbitration only the German wording shall be valid and binding.

Version: 1.00.01

Inhalt

1	General Information	4
2	Declaration of Conformity	4
3	Safety Instructions	5
3.1	Intended Use.....	5
4	Information and Safety Instructions for Using the Unit in Hazardous Areas	5
5	Warranty	6
6	Warning Signs and Definitions	6
7	Introduction	8
7.1	Serial Number	8
8	Application	8
9	Technical Data	9
10	Descripton	9
10.1	Gas Flow Diagram of the Supply Unit ILA SU-G10 EX	10
11	Receiving and Storing of the Device	11
12	Preparations for Installation	11
13	Installation	11
14	Connecting the Purge Gas Inlets and Outlets	12
15	Preparations for Commissioning	13
16	Start-up	14
17	Closing Down	14
18	Maintenance	15
18.1	Checking and Changing the Internal Fine Filter Element	15
18.2	Cleaning the Supply Unit	16
19	Instructions for Returning the Supply Unit	16
20	Proper Disposal of the Device	16
21	Spare Parts List	16
22	Risk Assessment	17
23	Annex	18

Table of Contents

Figure 1: Dimensions (internal assembly may vary)	10
Figure 2: Gas flow diagram ILA SU-G10 EX (assembly may vary).....	10
Figure 3: Schematic drawing of the in-situ analyzer with purge gas inlets and outlets	12
Figure 4: Interior view (internal assembly may vary)	13
Figure 5: Overview risk assessment.....	17

HEAD OFFICE

M&C TechGroup Germany GmbH ♦ Rehhecke 79 ♦ 40885 Ratingen ♦ Germany

Telephone: 02102 / 935 – 0

E - mail: info@mc-techgroup.com

www.mc-techgroup.com

1 General Information

The product described in this manual has been built and tested in our production facility.

All M&C products are packed to be shipped safely. To ensure the safe operation and to maintain the safe condition, all instructions and regulations stated in this manual need to be followed. This manual includes all information regarding proper transportation, storage, installation, operation and maintenance of this product by qualified personnel.

Please follow all instructions and warnings closely.

Please read this manual carefully before commissioning and operating the device. If you have any questions regarding the product or the application, please don't hesitate to contact M&C or your M&C authorized distributor.

2 Declaration of Conformity



The product described in this operating manual complies with the following EU directives:

ATEX-Directive

The product described in this manual is produced in accordance with the EU directive for devices and protection systems for appropriate use in hazardous areas 2014/34/EU.

Declaration of Conformity

The EU Declaration of conformity can be found in the annex of this manual. It can also be downloaded from the **M&C** homepage or directly requested from **M&C**.

3 Safety Instructions

Follow these safety directions and instructions regarding installation, commissioning and operation of this device:

Read this manual before commissioning and operating the product. Please make sure to follow all safety instructions.

Attention must be paid to the declaration of conformity in the annex of this instruction manual.

For use in hazardous area, observe the relevant national and international directives and regulations.

Operate the device only in the permitted temperature and pressure ranges.

Install the device only in protected areas, sheltered from rain, sun and moisture. The product should not be exposure to the elements.

If harmful gases are conveyed in the supply unit, appropriate safety measures must be taken in the event of leaks (e.g. leaking connections). Personal protective equipment must be adapted to the hazards at the installation site.

Only gases that cannot react in any way with the materials of the gas-carrying parts are to be conveyed in the supply unit.

Installation, maintenance, inspections and any repairs of the devices must be carried out only by qualified skilled personnel in compliance with the current regulations.

3.1 Intended Use

The pneumatic supply unit may only be operated in compliance with the information in chapter 4 and 9. Only use the device within the permitted temperature and pressure ranges.

Do not use this product for any other purpose. Improper use and handling can create hazards and cause damage. For more information, please refer to the safety information in this instruction manual.

4 Information and Safety Instructions for Using the Unit in Hazardous Areas

For detailed information see the declaration of conformity in the appendix. Installation and operating of the supply unit have to be done corresponding to the conditions specified in the declaration of conformity. Only in this case the reliability of the operation in the hazardous area can be guaranteed.



Any modification of the standard configuration of the device with parts, which are not approved by M&C and not explicitly specified for usage in explosive atmospheres, will void the Type Examination Certificate. This also refers to any repair work and service using parts which are not M&C approved and not specified for usage in explosive atmospheres.

*- Please don't hesitate to contact **M&C** or your **M&C distributor** if you have any questions about parts, service and repair work of the device.*

5 Warranty

In case of a device failure, please contact immediately M&C or your M&C authorized distributor. We have a warranty period of 12 months from the delivery date. The warranty covers only appropriately used products and does not cover the consumable parts. Please find the complete warranty conditions in our terms and conditions.

The warranty includes a free-of-charge repair in our production facility or the free replacement of the device. If you return a device to M&C, please be sure that it is properly packaged and shipped with protective packaging. The repaired or replaced device will be shipped free of delivery charges to the point of use. Do not send the heat exchangers with the device.

6 Warning Signs and Definitions



Danger

The 'Danger' warning sign indicates that death, serious injury and/or significant material damage will be the consequence, if the appropriate precautions should not be taken.



Warning

The 'Warning' warning sign indicates that death, serious injury or damage to property may occur if the relevant precautionary measures are not observed.



Caution

The 'Caution' warning sign indicates that slight personal injury can occur if the appropriate safety precautions are not observed.

Caution

'Caution' indicates that damage to property can occur if the appropriate safety precautions are not observed.

Attention

This means that an unintentional situation or an unintentional status may occur in case the respective note is not respected.



'Ex' indicates important information about the product or about the corresponding parts in the instruction manual, relating to usage in potentially explosive atmospheres.



Note

'Note' indicates important information relating to the product or highlights parts of the documentation for special attention.

Qualified personnel

'Qualified personnel' are experts who are familiar with the installation, commissioning, maintenance and operation of these types of products. The following knowledge is at least required for the work:

- Instructed person in EX-protection
- Trained person in the electrotechnical field
- Detailed knowledge of the manual and the applicable safety regulations



Toxic!

Danger to life if swallowed, in contact with skin or inhaled!

Do not swallow toxic substances, avoid skin contact and do not inhale toxic vapors. It is **MANDATORY** to take appropriate measures to reduce the risk and for personal protection.



Corrosive!

Risk of severe skin burns and serious eye damage! Living tissue and many materials are destroyed on contact with this chemical.

Do not inhale vapors and avoid contact with skin, eyes and clothing! It is **MANDATORY** to take appropriate measures to reduce the risk and for personal protection.



Use protective gloves!

Risk of injury from corrosive, hot or sharp objects!

Use adequate hand protection when working with chemicals, sharp objects or extreme temperatures.



Wear safety goggles!

Risk of injury to the eyes from splashes or flying particles!

Use suitable safety goggles.



Wear protective clothing!

Risk of injury from corrosive, hot or sharp objects!

Wear adequate protective clothing when working with chemicals, sharp objects or extreme temperatures.



Use safety shoes!

Risk of injury from falling objects, slippery floors or sharp objects on the floor!

Wear safety shoes with a suitable safety class.



Use head protection and full safety goggles!

Risk of injury from falling objects and splashes or flying particles from all directions.

Wear a helmet and full safety goggles when working with heavy equipment and where there is a risk to the eyes from splashes or flying particles from all directions.

7 Introduction

The pneumatic supply unit ILA SU-G10 EX is suitable for discontinuous and continuous oxygen measurements in dry and particle-free gases at varying locations.

The supply unit must not be used to extract gases or gas mixtures that may be explosive even in the absence of air or that alter the safety-relevant material properties.



Furthermore, these gases or gas mixtures must not contain any solids that could generate flammable friction or impact sparks in combination with the materials of the supply unit.

No potential ignition sources (e.g., smoldering or burning particles, smoldering nests, foreign objects) may enter the supply unit during operation.

7.1 Serial Number

The type plate with the serial number is located on the left-hand side panel of the supply unit. Always quote the serial number of the supply unit when making enquiries or ordering spare parts.

8 Application

The ILA1-X000-EX in-situ laser analyzer must be continuously purged with purge gas during operation. The laser head and the buffer zone are purged to remove gases that could affect the measurement. The wedge windows and the retroreflector in the measuring section are purged to prevent dust deposits. The pneumatic supply unit supplies the ILA1-X000-EX in-situ laser analyzer with the required purge gas.

9 Technical Data

Supply unit	ILA SU-G10 EX
Part No.	04A4040
Pneumatic connections	M6 Swagelok®
Purge gas IN	3-8 bar, Nitrogen or compressed air (dry, dust and oil free) depending on laser analyzer version
Purge gas flow: measuring section	0 to 13 l/min
Pressurized enclosure: sensor head	0.1 bar higher than ambient pressure (when using the ILA1-X000-EX in potentially explosive atmospheres)
Pressurized enclosure: puffer zone	1 bar higher than process pressure
Pressure regulator: sensor head	Regulation range of the pressurized enclosure from 0 to 0.7 bar
Pressure regulator: puffer zone	Regulation range of the pressurized enclosure from 0 to 6.8 bar
Ambient pressure	700 to 1200 hPa
Air humidity	RH < 99 %, non-condensing
Ambient temperature	-20 to +60 °C [-4 to +140 °F]
Storage temperature	-40 to +70 °C [-40 to +158 °F]
ATEX marking	II 3G Ex IIC Gc (see EU Declaration of Conformity in the annex)
Degree of protection	In accordance with IP65
Dimensions (W x H x D)	Approx. 600 x 760 x 210 mm without wall brackets and pneumatic connections
Weight	Depending on the configuration and size of the supply unit

10 Description

The pneumatic supply unit is equipped with a purge gas inlet. The purge gas inlet supplies the measuring section, the buffer zone, and the sensor head with purge gas. The purge gas creates excess pressure in the buffer zone and sensor head, which prevents process gases from entering.

The overpressure in the buffer zone must be at least 1 bar higher than the process pressure, and the overpressure in the sensor head must be higher than the ambient pressure. Since the process pressure and the ambient pressure can be different, the overpressure for the buffer zone and sensor head must be set separately.



Note

If the ILA1-X000-EX in-situ laser analyzer is used in an EX area, the overpressure in the sensor head must not exceed 100 mbar. Please refer to the operating instructions for the ILA1-X000-EX.

In the event of a purge gas pressure loss, both the buffer zone and the laser head are equipped with a check valve.

The wedge windows and retroreflector are purged during the process to remove particles that could interfere with the measurement. The purge gas flow rate can be adjusted from 0 to 13 l/min.

In addition to the pneumatic supply units, M&C also offers the SU EL10, SU EP10, and SU EP10 EX electrical supply units for the ILA1-X000-EX in-situ laser analyzer for the electrical connection of the laser head and the optional HMI.

The electrical and pneumatic supply units were specially developed for connection to the ILA1-X000-EX in-situ laser analyzer. Thanks to the explosion-proof versions, they can also be used in potentially explosive atmospheres.

Further information about the ILA1-X000-EX in-situ laser analyzer and the HMI can be found on our website or directly from M&C.

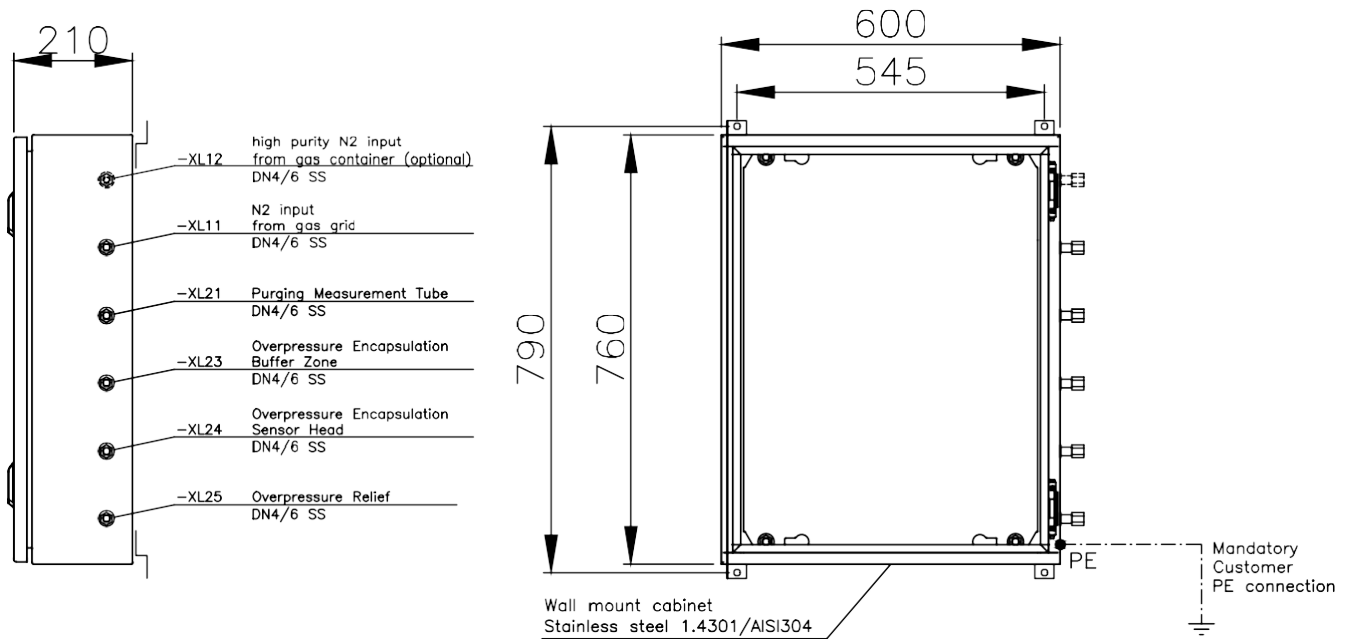

Figure 1: Dimensions (internal assembly may vary)

10.1 Gas Flow Diagram of the Supply Unit ILA SU-G10 EX

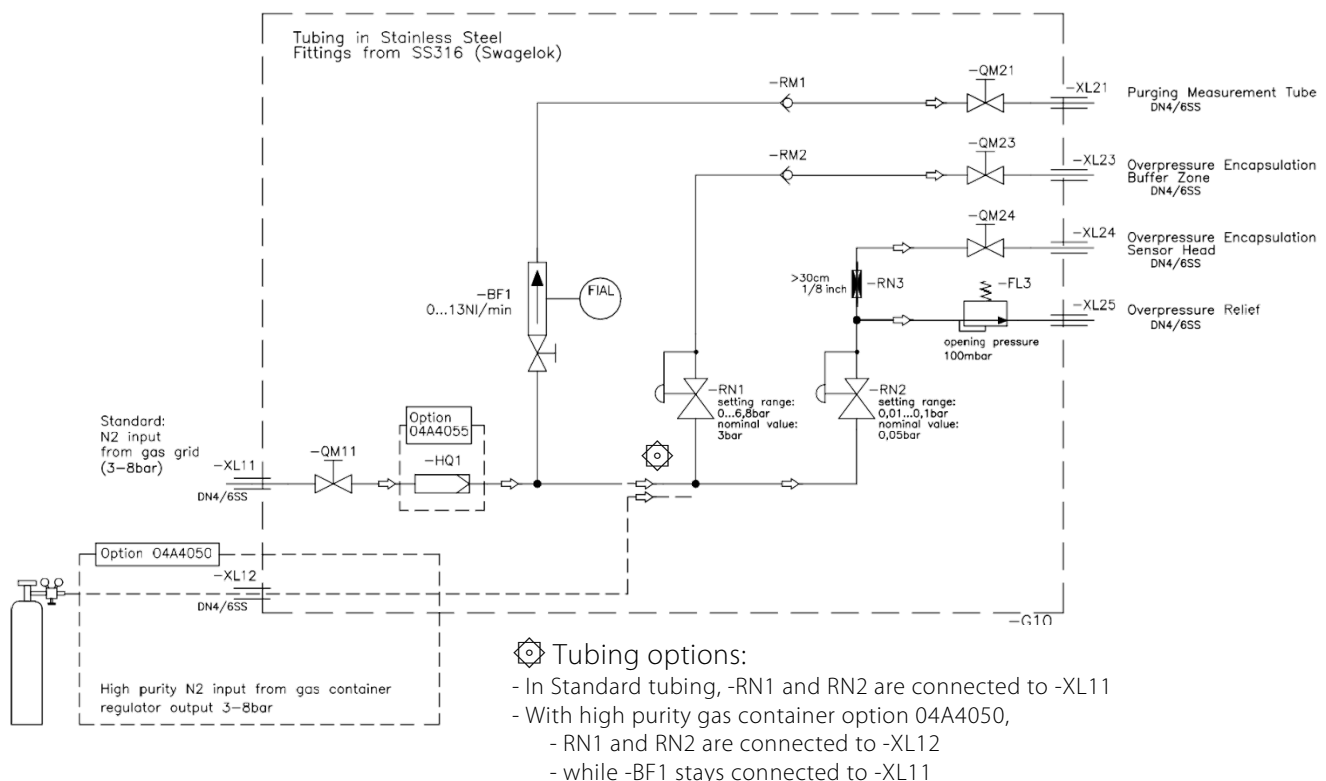

Figure 2: Gas flow diagram ILA SU-G10 EX (assembly may vary)

11 Receiving and Storing of the Device

The pneumatic supply unit ILA SU-G10 EX is a complete pre-installed unit.

- Carefully remove the supply unit and any special accessories from the shipping packaging immediately upon arrival and check the scope of delivery according to the delivery bill.
- Check the goods for any transport damage and, if necessary, inform your transport insurer immediately of any damage!



Note

The pneumatic supply unit must be stored in a weather protected frost-free area!

12 Preparations for Installation

The gases or gas mixtures must also not contain any solid particles that could generate flammable friction or impact sparks in combination with the supply unit.



It is not permitted for potential ignition sources (e.g. floating or burning particles, glowing embers, foreign bodies) to be introduced into the supply unit during operation.

It must be ensured that the temperature class of the supply unit corresponds to the ignition temperatures of the flammable gases/vapors.

13 Installation



Warning

Work on the gas sample probe may only be carried out by QUALIFIED PERSONNEL if the process and the surrounding area have been declared an explosion-free zone—free of explosive atmospheres.

Qualified Personnel

The supply unit must be connected to earth. The leakage resistance must be $< 10^6 \Omega$ throughout.



The supply unit must be installed and operated in such a way that electrostatic charges caused by operation, maintenance, or cleaning are prevented.

The ILA SU-G10 EX supply unit is designed for wall mounting near the ILA-X000-EX in-situ laser analyzer. Secure the supply unit using suitable materials appropriate for the load.

Ensure that the supply unit is easily accessible so that necessary maintenance work can be carried out without difficulty.



Caution

Depending on the design of the in-situ laser analyzer, nitrogen or instrument air is used as purge gas. Use nitrogen or instrument air for SO₂ measurements. Use only nitrogen for O₂ measurements.

Only use high-quality purge gas. Contaminants can damage the in-situ laser analyzer. The purge gas must be dry and free of dust and grease.

14 Connecting the Purge Gas Inlets and Outlets

The purge gas inlet and the three purge gas outlets for the measuring section, the buffer zone and the sensor head are located on the right-hand side. All connection fittings are made of SS316 (Swagelok®).

- Connect the purge gas inlet (3-8 bar) to the corresponding nitrogen or instrument air supply.
- Connect the purge gas outlets to the corresponding connections on the in-situ analyzer.

Attention

Do not kink the connecting flexible tubing.
Always use a support sleeve when connecting flexible tubing to stainless steel tube fittings.
The connection must be checked for leaks.

Details are shown in the following drawing.

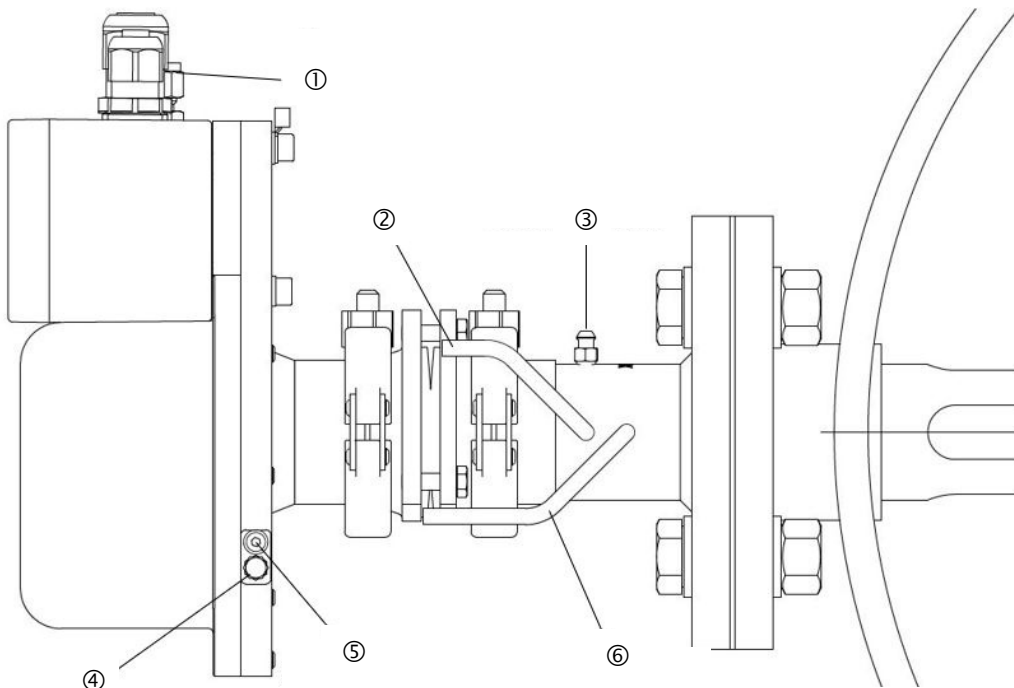

- | | |
|---|--|
| ① Purge gas inlet for the laser head | ② Purge gas inlet for the buffer zone (figure without Swagelok® connector) |
| ③ Venting screw on the buffer zone (purge gas outlet) | ④ Venting screw on the laser head (purge gas outlet) |
| ⑤ Screw for securing the venting screw | ⑥ Purge gas inlet for the measuring section (figure without Swagelok® connector) |

Figure 3: Schematic drawing of the in-situ analyzer with purge gas inlets and outlets

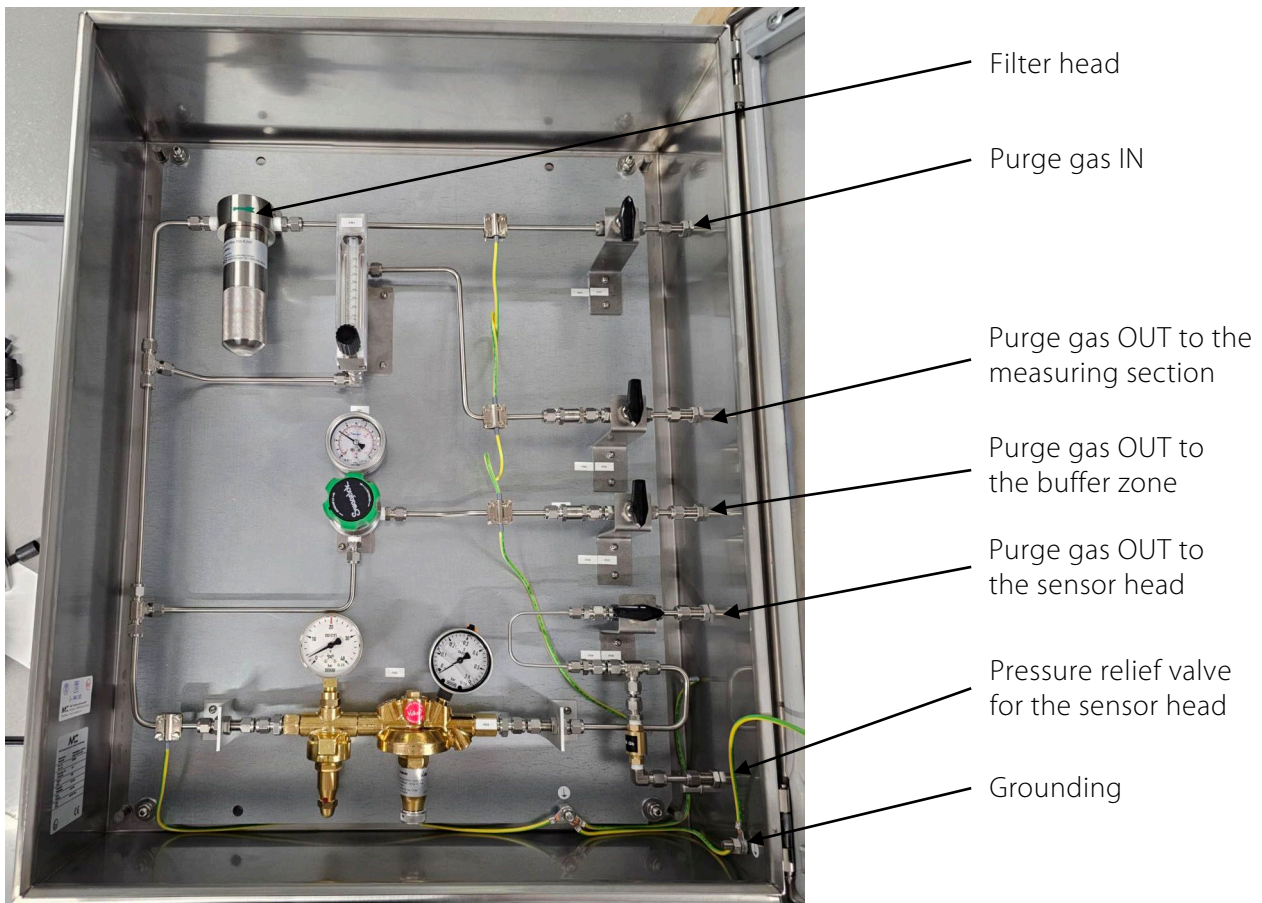

Figure 4: Interior view (internal assembly may vary)

15 Preparations for Commissioning

Before initial startup, all plant- and process-specific safety measures must be observed. It is mandatory for the operator to complete the enclosed risk assessment of the product.

The gas exposure risk must be assessed by the operator with regard to the hazards posed by process and calibration gas and the setup at the installation site (e.g. tubing, system cabinet/container/plant). If the risk assessment reveals increased exposure hazards, further measures are required.

A visible label must be attached to the installation site in accordance with the risk assessment provided by the operator.

16 Start-up

When selecting the gases or gas mixtures to be used as purge gases, reactions with the environment and the process must be ruled out.



The gases or gas mixtures must not contain any solid particles which, in combination with the materials of the supply unit, could generate flammable friction or impact sparks.

It is not permitted for potential ignition sources (e.g. smoldering or burning particles, glowing embers, foreign bodies) to be introduced into the supply unit during operation.

Follow the steps below:

1. Ground the housing of the supply unit.
2. Check the gas connections for leaks.
3. Open the nitrogen or instrument air supply.
4. Set the pressures according to the technical data table.

17 Closing Down



Danger

The escape of potentially harmful gases from the open gas connections after disassembly must be prevented.



The relevant safety regulations must be observed for the media to be pumped. If necessary, purge the tubes with suitable inert gas.

No special measures need to be taken when decommissioning the supply unit.

18 Maintenance



Warning

Work on the supply unit may only be carried out by QUALIFIED PERSONNEL if the process and the surrounding area are declared an explosion-free zone - free from potentially explosive atmospheres.

Qualified personnel



If toxic or oxygen-displacing gases are conveyed in the supply unit, the gas paths must be purged with inert gas or air before the gas-carrying parts are opened. In addition, the company's health and safety regulations must be observed.



For general mechanical work on the supply unit, wear personal protective equipment (PPE) in accordance with the risk assessment.

The system and process-specific safety measures must be observed before carrying out any maintenance work!

The supply unit does not require intensive and extensive maintenance. The pressure of the purge gas should be checked regularly, the fine filter element should be checked and replaced if necessary and the housing of the supply unit should be cleaned.



Note

Ensure that the tube fitting is tight!
If necessary, include the tightness of the tube fittings in the maintenance cycle.

The ILA1-X000-EX in-situ laser analyzer must be serviced regularly. For information on maintaining the in-situ laser analyzer, please refer to the corresponding instruction manual.

18.1 Checking and Changing the Internal Fine Filter Element

The fine filter element integrated in the supply unit should be checked regularly for dirt and replaced if necessary. To change it, the unit must be opened as follows:

1. Unlock the supply unit with the enclosed key and open the door.
2. The filter head is attached to the inside of the housing. The filter body can be removed. Unscrew the filter body.
3. Unscrew the filter element holder and check/replace the filter element.
4. Check the O-ring seal. Replace the O-ring if necessary.
5. Screw in the filter element holder with the new filter element.
6. Screw in the filter body.
7. Close the door and lock the supply unit with the enclosed key.

18.2 Cleaning the Supply Unit

The housing of the supply unit must be checked for dust deposits at suitable intervals. Dust layers greater than 5 mm must be removed immediately. Dust deposits on the inside must also be removed.



Warning

To avoid static charges, always clean with a damp cloth.

19 Instructions for Returning the Supply Unit



Note

Please use the return form on our homepage at: [Return of Products | M&C TechGroup](#)

Prior to return shipment, the device must be cleaned of hazardous or highly aggressive contaminants.

20 Proper Disposal of the Device

At the end of the service life of our products, it is important to take care of the appropriate disposal of obsolete electrical and non-electrical devices. To help protect our environment, follow the rules and regulations of your country regarding recycling and waste management.

21 Spare Parts List

Wear, tear and replacement part requirements depend on specific operating conditions. The recommended quantities are based on experience, and they are not binding.

Supply unit for purge gas ILA SU-G10 EX					
(C) Consumable parts (R) Recommended spare parts (S) Spare parts					
		Recommended quantity being in operation [years]			
Part No.	Indication	C/R/S	1	2	3
90A0100	Filter element 0.1 µm glass fiber	C	4	8	12
90A0068	O-ring built-in filter	R	2	4	6
90A0015	Flow meter glass 7-70 NI/h	R	-	-	1

22 Risk Assessment

The risk assessment provided in this chapter is intended for all work activities on the product. The hazards can occur in the work steps of assembly, commissioning, maintenance, disassembly and in the event of a product fault. During normal operation, the product is protected by a system cabinet or appropriate covers. Only qualified personnel is permitted to perform the work. The following minimum knowledge is required for the work:

- Employee instruction provided in process engineering
- Employee instruction provided in electrical engineering
- Detailed knowledge of the instruction manual and the applicable safety regulations

The product complies with the current regulations according to state-of-the-art science and technology. Nevertheless, not all sources of danger can be eliminated while observing technical protective measures. Therefore, the following risk assessment and the description of exposure hazards refer to the work steps mentioned above.

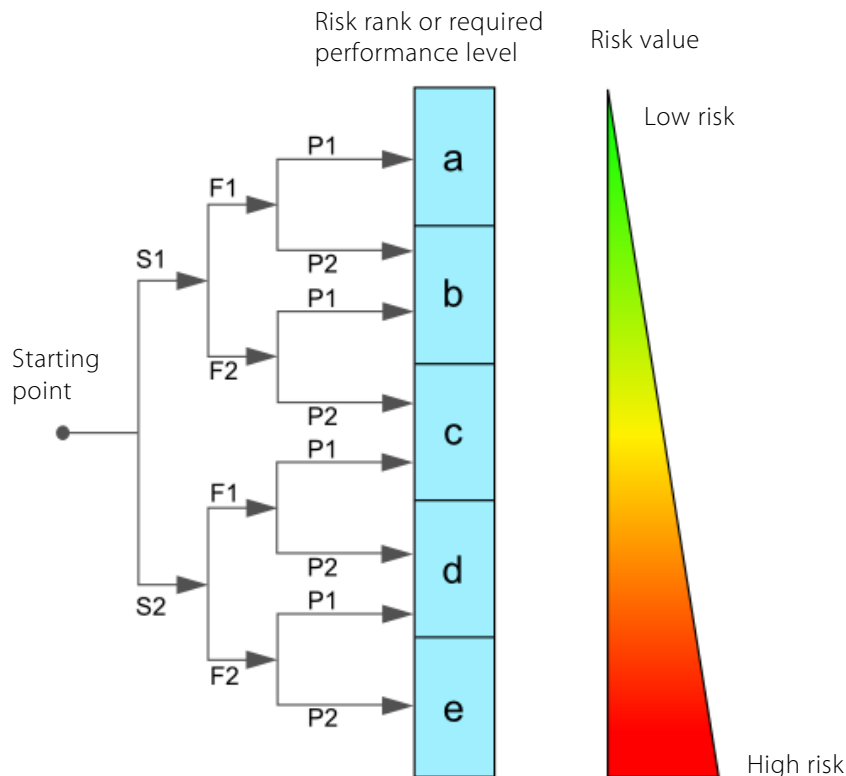

Severity of injury:

S1 = 1 = minor (reversible injury)

S2 = 2 = serious (irreversible injury, death)

Frequency and duration:

F1 = 1 = infrequent or short exposure to hazard

F2 = 2 = frequent (more than once per hour/shift)

Possibility of preventing or limiting the damage

P1 = 1 = possible

P2 = 2 = hardly possible

Figure 5: Overview risk assessment



Gas hazard

Risk rank group A-B-C

The hazard potential mainly depends on the gas to be extracted. If toxic gases, oxygen displacing or explosive gases are conveyed with the product, an additional risk assessment by the operator is mandatory.

In principle, the gas paths must be purged with inert gas or air before opening the gas-carrying parts.

The escape of potentially harmful gas from the open process connections must be prevented.

The relevant safety regulations must be observed for the media to be conveyed. If necessary, flush the gas-carrying parts with suitable inert gas. In the event of a gas leakage, the product may only be opened with suitable PPE or with a monitoring system.

Furthermore, the work safety regulations of the operator must be observed.



Caution crushing hazard

Risk rank group A

The work must be performed by trained personnel only.

This applies to products weighing less than < 40 kg [\approx 88.2 lbs]:

The product can be transported by 1 to 2 person(s). The instructions for appropriate personal protective equipment (PPE) must be observed.

The weight specifications are contained in the technical data of this product.

Furthermore, the work safety regulations of the operator must be observed.

23 Annex

- EU Declaration of conformity



Further product documentation can be seen and downloaded from our home page:
www.mc-techgroup.com.

EU – Konformitätserklärung EU Declaration of conformity

Die M&C TechGroup Germany GmbH erklärt hiermit, dass nachfolgende Produktgruppen, des Types
With this document, the M&C TechGroup Germany GmbH confirms, that the following product types of these product groups

Produkt Product	SU G10 EX, Spülgasversorgung für ILA1 X000 EX
Artikelnummer Item number	04A4040
Umgebungstemperatur Ambient temperature	-20°C to 60°C
ATEX	II 3G Ex IIC Gc
ATEX	

Im Aufbau den grundlegenden Anforderungen der nachfolgenden Richtlinien entsprechen
For erection comply with the essential requirements of the following directives

EU-Richtlinie 2011/65/EU EU-Directive 2011/65/EU	RoHS Richtlinie incl. Annex 2015/863 RoHS directive incl. Annex 2015/863
EU-Richtlinie 2011/34/EU EU-Directive 2011/34/EU	ATEX Richtlinie ATEX directive

Sowie die Übereinstimmung mit nachfolgenden Normen:
As well as in compliance with the following standards:

EN 61010-1:2010 + A1:2019 + A1:2019/AC:2019
EN IEC 60079-7:2015/A1:2018,
DIN EN ISO 80079-36,
EN IEC 63000:2018
EN 1127-1

Ratingen, den 02.07.2025

M&C TechGroup Germany GmbH

ppa. Jan-Christoph Rumm
Rehhecke 79
D-40885 Ratingen
www.mc-techgroup.com

Diese Erklärung bescheinigt die Übereinstimmung mit den genannten Richtlinien, beinhaltet jedoch keine Zusicherungen von Eigenschaften im rechtlichen Sinne.
This declaration certifies conformance with the above mentioned directives. Affirmation of attributes in a legal sense is not included.
Die Sicherheitshinweise und Installationsanweisung der mitgelieferten Produktdokumentation sind zu beachten.
The safety declarations and installation instruction of the accompanying product documentation need to be considered.